

# SERVICE

# MANUAL

AKAI TAPE RECORDER

MODEL

X-2000SD

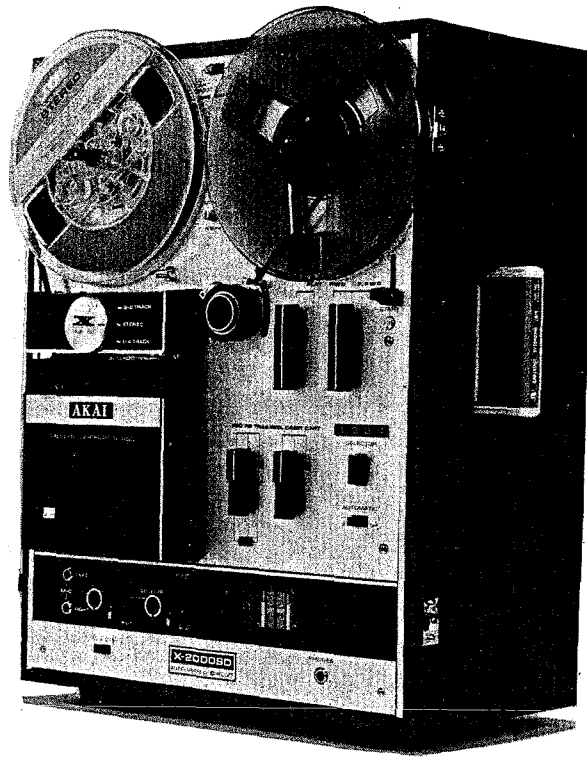

## TABLE OF CONTENTS

I	SPECIFICATIONS .....	1
II	MEASURING METHOD .....	3
III	CONTROL LOCATION .....	5
IV	DISMANTLING OF TAPE TRANSPORT UNIT & AMPLIFIERS .....	6
V	TRANSPORT MECHANISM .....	10
VI	MECHANISM ADJUSTMENT .....	12
VII	AMPLIFIER ADJUSTMENT .....	22
VIII	MAINTENANCE PROCEDURES .....	25
IX	COMPOSITE VIEWS OF COMPONENTS .....	26
X	TROUBLE SHOOTING CHART .....	30
XI	SCHEMATIC DIAGRAM	

# I. SPECIFICATIONS

WEIGHT	: 49.4 lbs (22.4 kg)
DIMENSIONS	: 10.6" (D) x 13.8" (W) x 18.3" (H) (270 (D) x 350 (W) x 465 (H) mm)
POWER SUPPLY	: 100 to 240 V AC ; 50/60 Hz
RECORDING SYSTEM:	Reel In-Line 4 track stereo monaural Cross-Field Head Recording System : Cartridge In-Line 8 track stereo recording system : Cassette In-Line 4 track stereo recording system : Transfer Pre-recorded conventional reel tape can be dubbed on the cartridge tape and cassette tape.
PLAYBACK SYSTEM :	Reel In-Line 4 track stereo/monaural playback system : Cartridge In-Line 8 track stereo playback system : Cassette In-Line 4 track stereo playback system
TAPE SPEED	: Reel 1-7/8, 3-3/4, 7-1/2 ips (15 ips optional) : Cartridge 3-3/4 ips : Cassette 1-7/8 ips
TAPE SPEED DEVIATION	: Within $\pm 3\%$ (Cassette +4%, -2%)
WOW AND FLUTTER :	Reel - Less than 0.2% (7-1/2 ips) Less than 0.3% (3-3/4 ips) Less than 0.35% (1-7/8 ips) : Cartridge - Less than 0.35% : Cassette - Less than 0.35%
FREQUENCY RESPONSE	: 30 to 22,000 Hz ( $\pm 3$ dB) at 7-1/2 ips 30 to 18,000 Hz ( $\pm 3$ dB) at 3-3/4 ips 30 to 9,000 Hz ( $\pm 3$ dB) at 1-7/8 ips : Cartridge 50 to 18,000 Hz ( $\pm 3$ dB) : Cassette 30 to 16,000 Hz ( $\pm 4$ dB)
SIGNAL TO NOISE RATIO	: Reel - Better than 48 dB : Cartridge - Better than 40 dB : Cassette - Better than 40 dB
DISTORTION	: Reel - 2% at 1000 Hz 0 VU 5% at 1000 Hz 10 W : Cartridge - 3% at 1000 Hz 0 VU : Cassette - 3% at 1000 Hz 0 VU
CROSS TALK	: Reel -40 dB at Stereo : Cartridge -50 dB : Cassette -25 dB

ERASE RATIO	: Reel - Less than -70 dB : Cartridge - Less than -60 dB : Cassette - Less than -60 dB
INSULATION RESISTANCE	: More than 50 M ohms
OUTPUT	: Line ... 1.228 V (+4 dB) 250 Hz Impedance ... 8 ohms : Required Load Impedance ... More than 25 K ohms : Power ... More than 5 W per channel
INPUT LEVEL	: Line ... More than 50 mV (-25 dB) Impedance ... 330 K ohms : Mic. ... 0.5 mV (-65 dB) Impedance ... 4.7 K ohms
DIN OUTPUT	: 0.4 V 250 Hz Impedance ... 10 K ohms : Required Load Impedance ... More than 50 K ohms
DIN INPUT	: High ... 50 mV (-25 dB) Impedance ... 330 K ohms : Low ... 5 mV (-45 dB) Impedance ... 39 K ohms
F. FORWARD & REWIND TIME	: 90 seconds using a 1200 ft. tape at 50 Hz 75 seconds using a 1200 ft. tape at 60 Hz
MOTOR	: Horse Power - (1/100 HP) : Power Ratio ... 70% : Revolutions 2900 to 1450 r.p.m. at 50 Hz 3480 to 1740 r.p.m. at 60 Hz : Condenser Capacity 2.5 $\mu$ F at 50 Hz 2.0 $\mu$ F at 60 Hz
HEADS	: Reel Recording/Playback ... 4 track (Gap 2/1000 mm) Impedance ... 1.2 K ohms at 1000 Hz Bias ... Gap 0.2 mm Impedance ... 0.5 K ohms at 60 Hz Erase ... (same as Bias Head) : Cartridge Recording/Playback ... 8 track (Gap 1 /1000 mm) Impedance ... 0.75 K ohms at 1 kHz Erase ... Gap 0.1 mm Impedance ... 0.21 K ohms at 90 kHz : Cassette Recording/Playback ... 4 track (Gap 1/1000 mm) Impedance ... 1 K ohms at 1000 Hz Erase ... Impedance 0.73 K ohms at 100 kHz

---

TRANSISTORS USED: 4 2SC458Lg (b) (c)  
2 2SC458 (b) (c)  
2 2SC971 (2) (3)  
1 2SD223 (V) (E)  
1 2SC536E (3)  
1 2SC968 (b)  
1 2SC1060

IC USED : 2 STK-011A (Main)  
2 AA-072 (Pre)

SILICON DIODES USED  
: 1 10 DC-1 Black  
1 10 DC-1 Red  
1 10 D-2  
1 10 D-1  
2 VO 6C

GERMANIUM DIODES USED  
: 7 1N46A  
2 1N34A  
1 19339M

RELAY USED : 2 MY-40-AD3  
1 Teck-32

## II. MEASURING METHOD

### TAPE SPEED DEVIATION

1. Method involving use of pre-recorded tape.

For measuring the tape speed deviation, play back the pre-recorded tape at 1,000 Hz  $\pm$  0.1%. Connect the appropriate output to a frequency counter meter in order to measure the tape speed deviation from the resulting deviation of the measured frequency.

2. Method involving use of timing tape. (designed for tape speed measurement)

This method utilizes a timing tape marked at intervals of 7-1/2". The running time of over 60 marked sections of tape is measured in order to calculate the deviation of the tape speed. In applying this method, however, it should be kept in mind that the timing tape stretch or contract measurement error is inevitable, so that it is necessary to measure the total length of the tape in advance.

### WOW AND FLUTTER

Playback the 3,000 Hz pre-recorded tape of which the wow and flutter level is guaranteed to be smaller than 0.07% for measurement by means of a wow meter. It is also possible for a 3,000 Hz sine wave to be recorded and played for measurement by means of the wow meter. In this case, however, the wow meter indicates a value as much as twice the value given in the specifications on the first page.

### SIGNAL TO NOISE RATIO

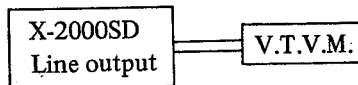

Set the Equalizer Switch on "7-1/2" ips position and playback a tape containing a 250 Hz sine wave recorded at "0" VU level on a standard recorder.

Connect a V.T.V.M. to the line output jack of the recorder and measure its output.

Then remove the tape and measure the noise level under the same condition. Convert each of the measured values into decibels.

### TOTAL HARMONIC DISTORTION FACTOR

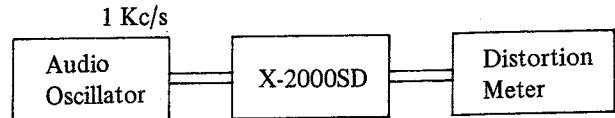

Connect the measuring instrument as shown above, and record the 1,000 Hz sine wave at "0" VU. Playback the resultant signal and measure the overall distortion factor. Measure the noise level of the tape recorder with the tape removed; connect the audio oscillator directly to the distortion meter for measurement of the distortion factor of the oscillator.

The required distortion factor may be obtained from the results of the above measurement by the following formula.

$$d_0 = d - d_1 - d_2$$

where,

- $d_0$  = Required
- $d$  = Overall distortion factor
- $d_1$  = Noise level
- $d_2$  = Distortion factor of the oscillator

(Note : New tape of particularly good quality should be used for measurement of the distortion factor.)

### POWER OUTPUT

Playback a tape containing a 1,000 Hz sine wave recorded at 0 VU on a standard recorder.

Connect a V.T.V.M. to the line output jack of the recorder and measure the voltage at the output of the recorder to be tested.

## CROSS TALK (Cross talk between the tracks)

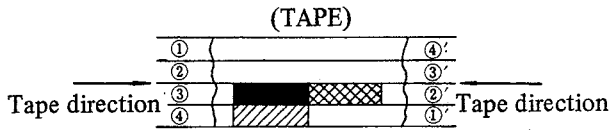

As shown in the figure, first record a 1,000 Hz sine wave on track No. 3 at +3 VU level. Next, remove the 1,000 Hz input signal and record under a non-input condition.

Then, playback the tape on track No. 3 and No. 1 (reversed condition of tape) through the 1,000 Hz B.P.F. (Band Pass Filter, Sensitivity ... 1 : 1) and obtain a ratio between the two from the following formula.

$$C = 20 \log \frac{E_0}{E_2 - E_1} \text{ (dB)}$$

- |   |  |   |
|---|--|---|
| { | C = Desired crosstalk ratio (dB)                 |   |
|   | E <sub>0</sub> = 1,000 Hz signal output level    | ■ |
|   | E <sub>2</sub> = 1,000 Hz crosstalk output level | ▨ |
|   | E <sub>1</sub> = No-input signal record level    | ▩ |

## FREQUENCY RESPONSE

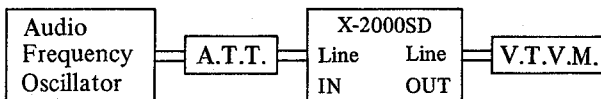

Connect the measuring instrument as in the above diagram, and measure the frequency response according to following sequence :

### RECORD :

- 1) Give a sine wave of 1,000 Hz to the Line Input of the recorder to be tested, through an attenuator from an audio frequency generator.
- 2) Set the Mode/Selector Knob to "Rec" position and adjust the line input volume so that the VU meter needle indicates "0" VU.
- 3) Under the condition described in (2), lower the input level 15 dB by means of the attenuator.
- 4) Record the spot frequency in the range of 30 Hz to 25,000 Hz from the audio frequency generator.

Note : Frequency Response of the Cassette tape is adjusted by the Bias Voltage (VR107, VR207 semi-fixed Resistor).

### PLAYBACK :

- 5) Set the Equalizer Switch on 7-1/2" or 3-3/4"
- 6) Connect a V.T.V.M. to the Line output.
- 7) Playback the tape previously recorded.
- 8) Adjust the output level to "0" dbm at 1,000 Hz as indicated on the V.T.V.M. by the range selector of a V.T.V.M.
- 9) Playback the recorded spot frequencies under the conditions in (8) , make a memo of output level and plot the value on a graph.



### III. CONTROL LOCATIONS

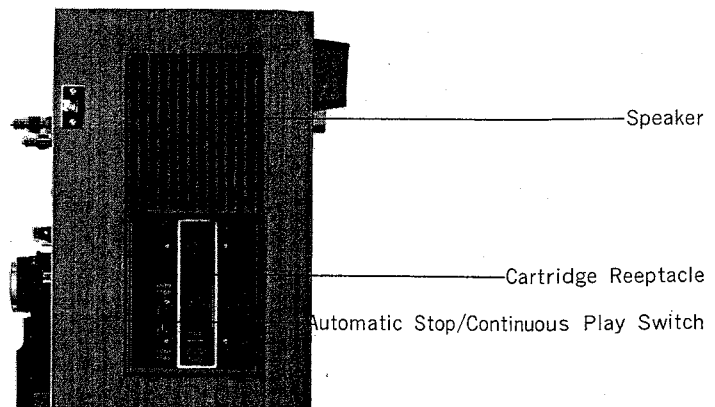
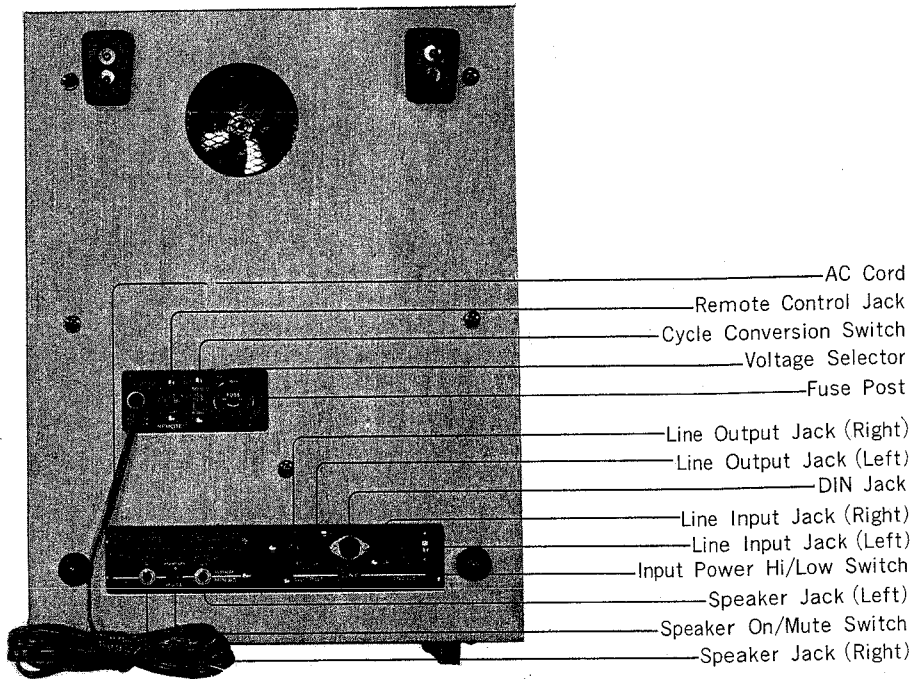
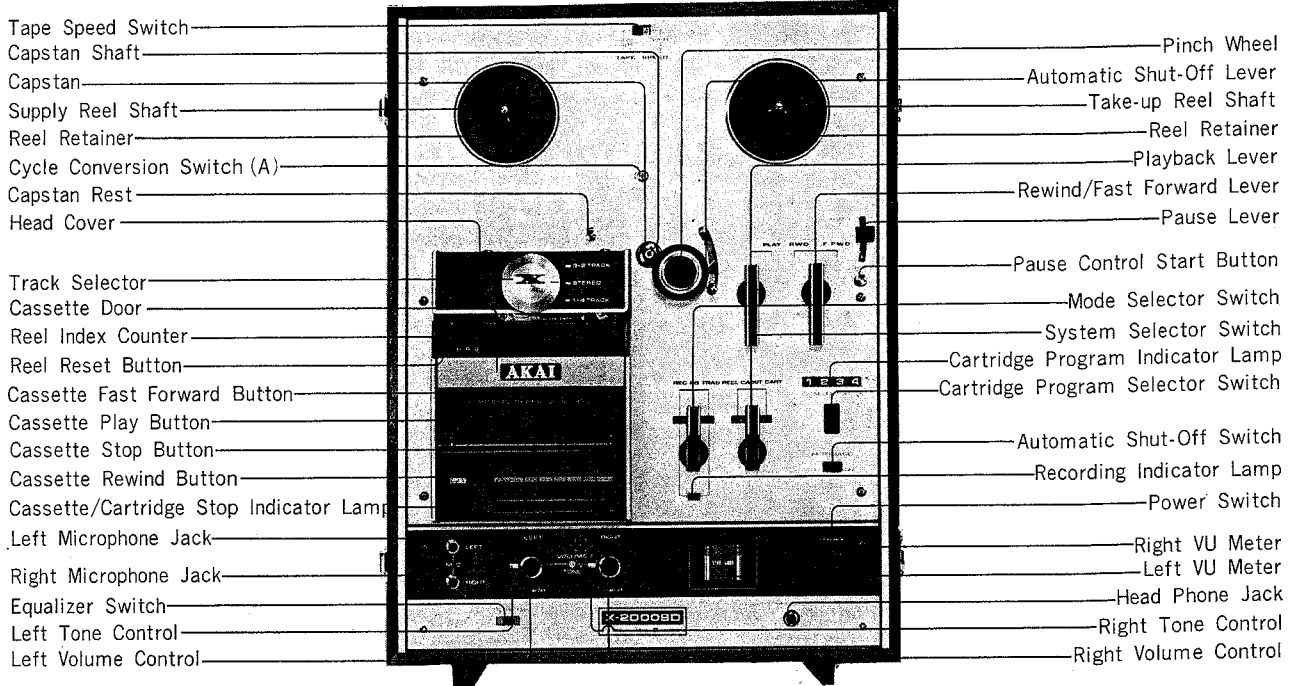

# IV. DISMANTLING OF TAPE TRANSPORT UNIT & AMPLIFIERS

In case of trouble, etc. necessitating disassembly, please disassemble in the order shown in photographs. Remantle in reverse order.

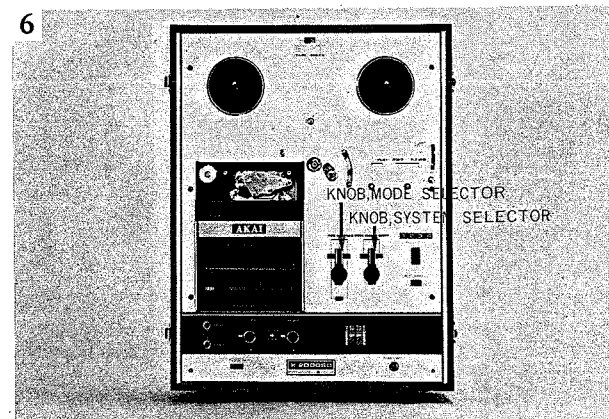
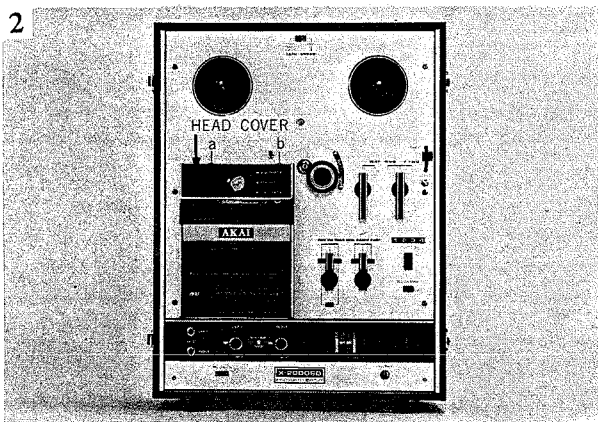



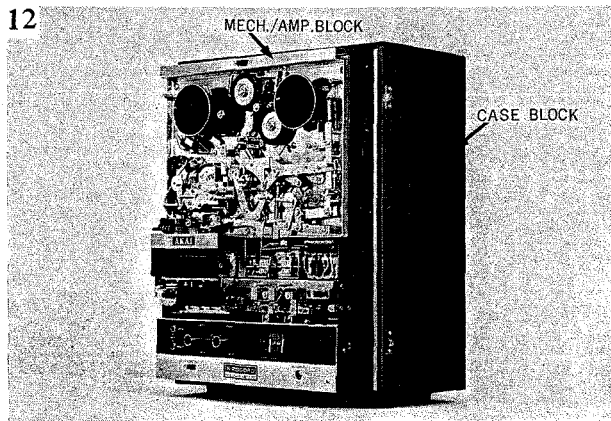
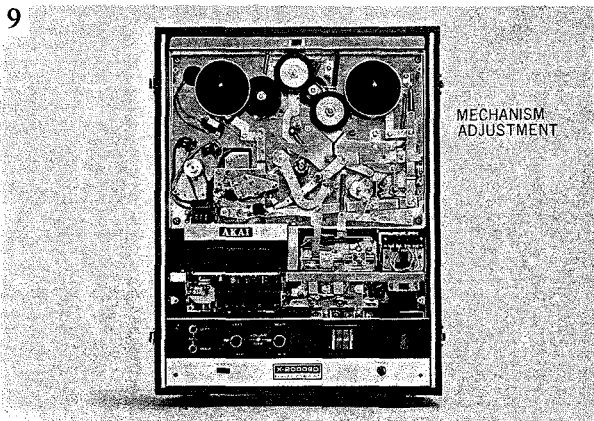
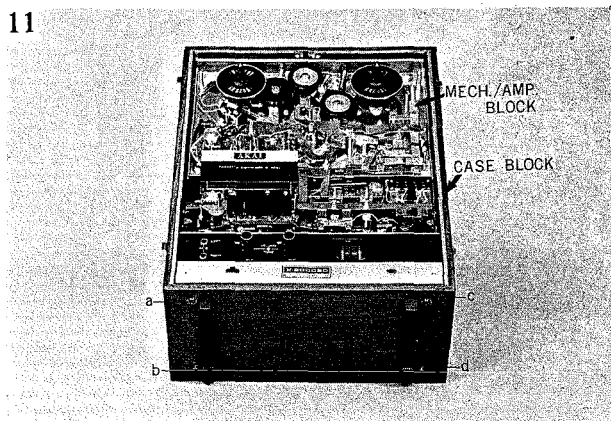
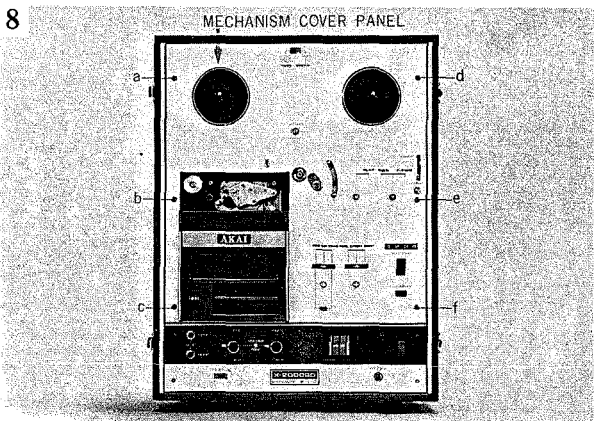
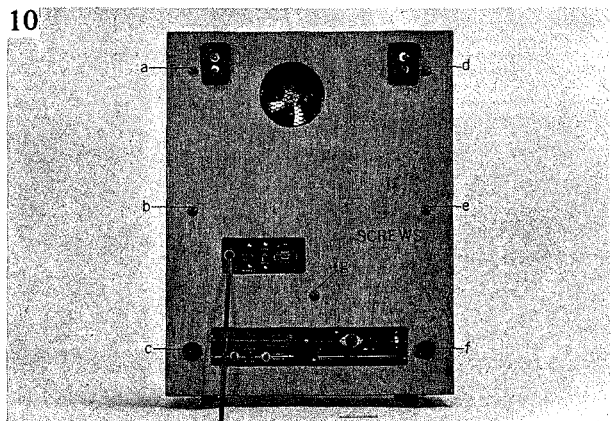
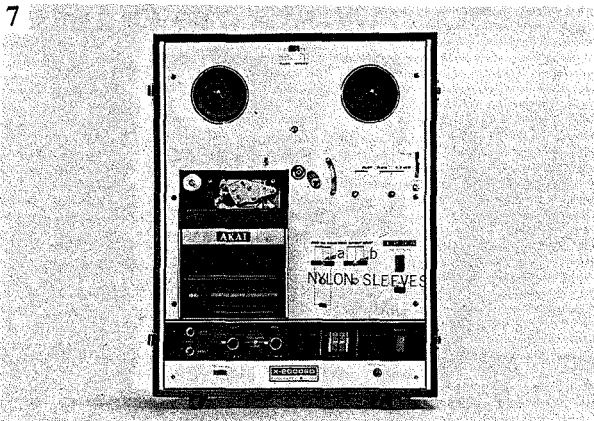

13

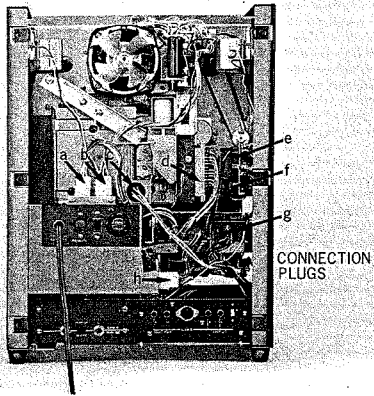

17

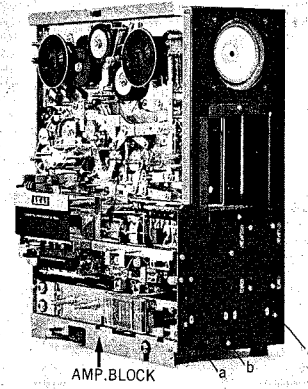

14

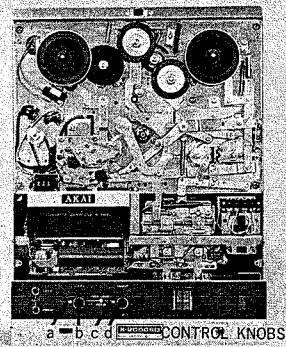

18

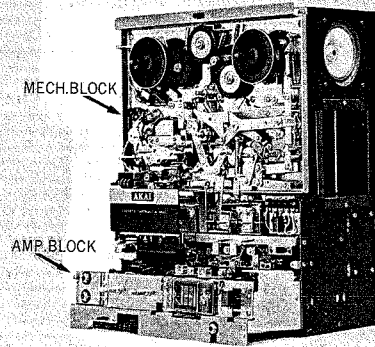

15

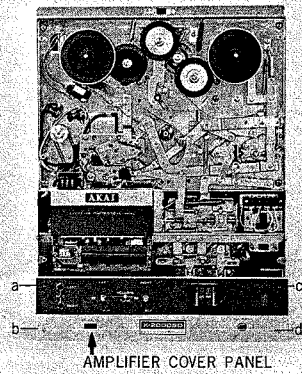

19

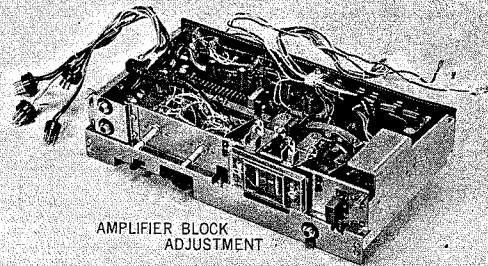

16



20

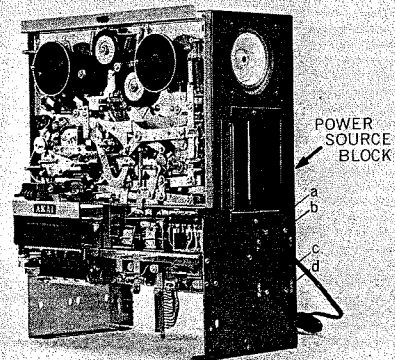

21

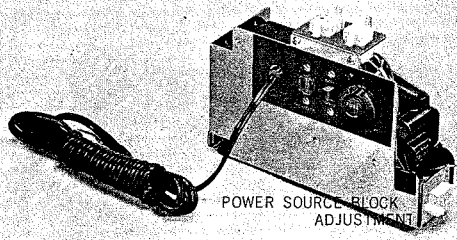

25

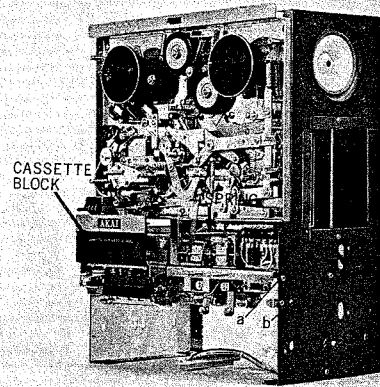

22

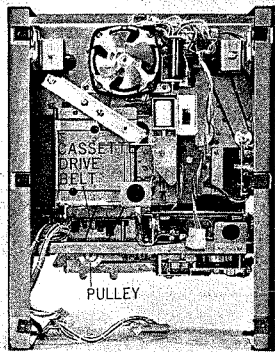

26

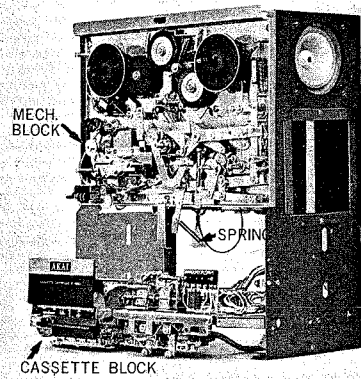

23

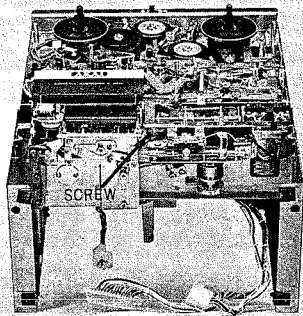

27

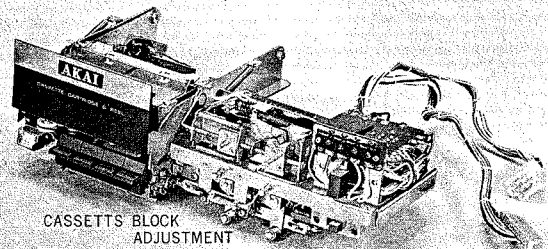

24

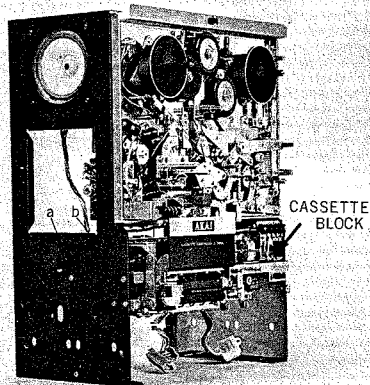

28

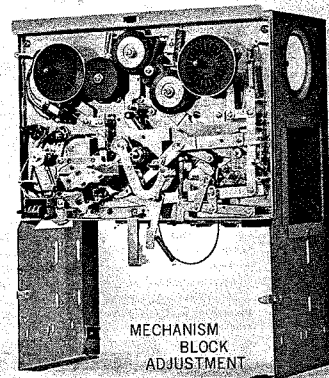

## V. TRANSPORT MECHANISM

### 1. CAPSTAN DRIVE

Figure 1.

- (A) Motor
- (B) Drive Belt (flat belt)
- (C) Capstan
- (D) Flywheel

High-speed rotation of Motor (A) is transmitted by Drive Belt (B) to Capstan (C), which is connected to a flywheel that provides necessary inertia. This flywheel maintains the rated rotation and absorbs minor rotation variations of the motor.

Capstan Rotation :

- 606 R.P.M. at 7-1/2" (19 cm) per sec.
- 303 R.P.M. at 3-3/4" (9.5 cm) per sec.
- 151.5 R.P.M. at 1-7/8" (4.75 cm) per sec.

Motor Rotation :

- 3,000 to 1,500 R.P.M. at 50 Hz
- 3,600 to 1,800 R.P.M. at 60 kHz

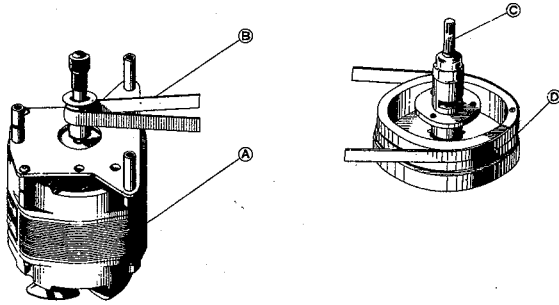

Fig. 1

### 2. PINCH WHEEL DRIVE

Place tape between the rotating capstan and pinch wheel and push pinch wheel against capstan to transport the tape at rated speed. The proper pinch wheel pressure is between 1,000 to 1,150 grams at the tape speed of 7-1/2" (19 cm) per second.

### 3. RECORD AND PLAYBACK MECHANISM

Turning the RECORD/PLAYBACK LEVER (A) to "PLAY" position causes the pinch wheel to press against the capstan and move the tape at the rated speed. At the same time, Idler (B) moves between Motor Bushing (C) and the Take-Up Reel Spindle (D) to transmit the motor rotation to (D) so that the tape is moved and wound on the take-up reel. The Take-up Reel Spindle Base, composed of two plastic wheels (discs) (1 and 2) with a felt clutch between, is rotated from below by the idler. Tape-winding friction is adjusted by the slipping of the felt and maintains rated winding of the tape. The Supply Reel Spindle (H) has a Brake Roller (E) contacting plastic wheel (disc) (4) from below which provides appropriate back tension by the slipping of the felt clutch to the rotation of the Pulley (3) above. To prevent accidental erasure, the Record Interlock Button (F) must be depressed before the RECORD/PLAYBACK LEVER can be moved to the "REC" position. Safety device (G) is depressed to operate the recording mechanism. (See figure 2)

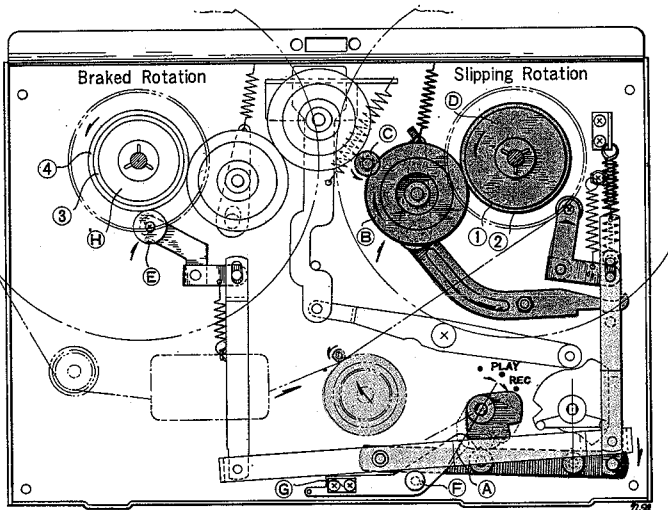

Fig. 2

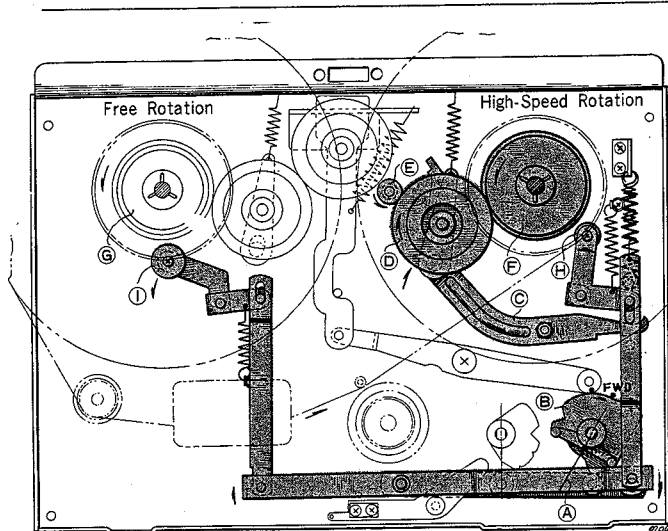

Fig. 3

#### 4. FAST-FORWARD MECHANISM

Turning the *FAST FWD-REWIND knob (A)* to "FAST FWD" position, causes the *cam (B)* under the knob to push up *Lever (C)*. *Idler (D)* moves into the space between *Plastic Roller (F)* above the *Take-Up Reel Spindle* and the upper part of the rotating motor drive bushing to transmit the motor rotation to the take-up reel spindle. At the same time, *Brake Rollers (H) and (I)* comes off the reel spindle to free the *Supply Reel Spindle (G)*, thereby allowing fast winding of the tape onto the take-up reel. (See figure 3)

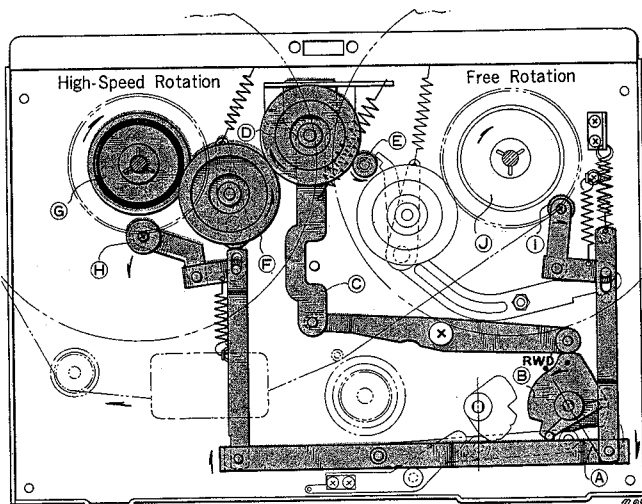

Fig. 4

#### 5. REWIND MECHANISM

Turning the *FAST FWD-REWIND knob (A)* to "REWIND" position, causes the *cam (B)* under the knob to push *Lever (C)* up. *Idler (D)* moves into the space between the upper part of the rotating *Motor drive bushing (E)* and the *Intermediate Pulley (F)* to transmit the high-speed rotation of the motor through the intermediate pulley to the *Supply Reel Spindle (G)*. At the same time, *Brake Rollers (H) and (I)* come off the reel spindle to free the *take-up reel spindle (J)*, thereby rewinding the tape onto the supply reel at a fast speed. (See figure 4)

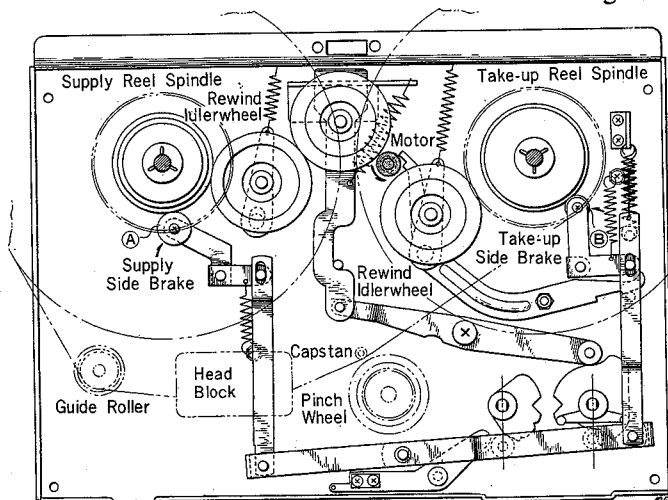

Fig. 5

#### 6. STOP CONTROL

Turning the stop lever to the "STOP" position, causes *Brake Rollers (A) and (B)* to depress the reel spindles and stop rotation. As the brake rubbers depress the plastic rollers below the reel spindles, no friction is applied to the tape. (See figure 5)

Modes of Operation	Pinch Wheel	Take-up Idler Wheel	Rewind Idler Wheel	Take-up side Brake	Supply side Brake
(a) STOP	X	X	X	○	○
(b) FAST-FORWARD	X	○	X	X	X
(c) REWIND	X	X	○	X	X
(d) RECORDING PLAYBACK	○	○	X	X	○

NOTES : X-marks indicates "open" and  
○-marks "engaged"



## VI. MECHANISM ADJUSTMENT

### 1. PINCH WHEEL ADJUSTMENT

It is important that the pinch wheel shaft be kept in perfect alignment with the capstan shaft. Proper pinch wheel pressure is between 1,000 and 1,150 grams when the unit is operated at the tape speed of 7-1/2 ips. Any deviation from this specification will result in wow and flutter. Check pinch wheel pressure by a spring scale, and if necessary, adjust the pinch wheel load spring.

### 2. TAKE-UP IDLER WHEEL ADJUSTMENT

The take-up idler wheel must be kept in perfect alignment with the take-up reel shaft. In fast forward operation, the idler wheel contacts the upper knurled wheel of the take-up reel shaft assembly, and conversely contacts the lower knurled wheel during record or play operation. Adjust idler wheel load spring so that the idler wheel pressure is kept between 50 and 80 grams. The idler wheel wears rapidly if the pressure is excessive. Slippage occurs if the pressure is less than specified.

### 4. INTERMEDIATE WHEEL ADJUSTMENT

The intermediate wheel is located between the rewind idler wheel and the rubber ring which is used on the upper part of the supply reel shaft assembly. In rewind condition, it contacts these parts while simultaneously transmitting motor torque. An adequate pressure is 50 grams. Adjust the load spring of the intermediate wheel if the pressure is not sufficient.

### 5. TAKE-UP REEL SHAFT ASSEMBLY ADJUSTMENT

Felt clutch material is attached to the bottom side of the reel table base plate so that recording tape will not stretch during fast forward operation due to excessive tension. To check the amount of friction of this part, install a 5-inch reel with a 60 m/m diameter tape, and gently pull the end of tape upward with a spring scale. Adjust the conical spring so that the amount of tension at this part is kept between 400 and 500 grams. Other felt clutch material is attached to the take-up drive wheel. This is to provide proper slippage during record or play operation. The procedure for checking friction of this part is the same as the foregoing, and between 150 and 200 grams of friction provides the best results. Adjust the star-shaped spring just under the take-up drive wheel. When the unit is set to rewind operation, the amount of friction of this part will decrease to from 15 to 20 grams. Check to see whether this is satisfactory. If not, readjust the star-shaped brake spring and the pressure of the spring retainer washer accordingly.

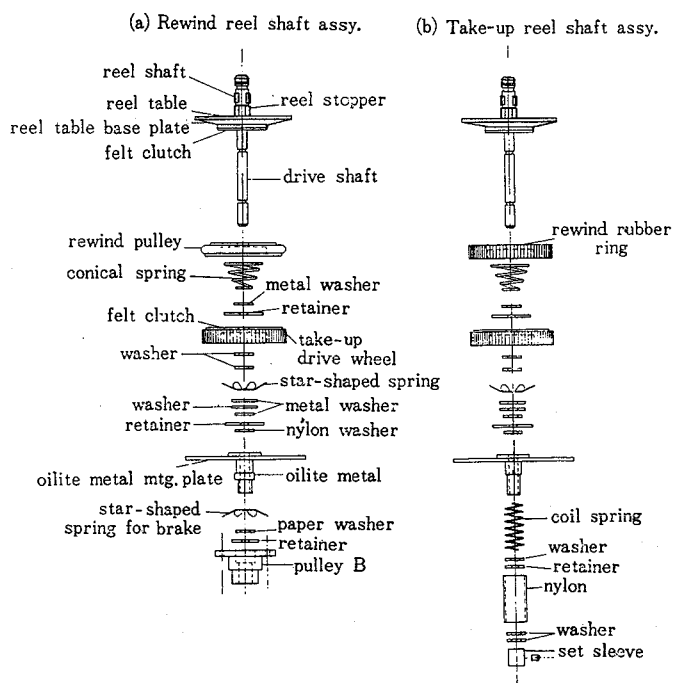

Fig. 1

### 3. REWIND IDLER WHEEL ADJUSTMENT

The rewind idler wheel must be kept in perfect alignment with the rewind reel shaft. The amount of pressure on the knurled motor bushing should be about 50 grams during rewind operation. Adjust both the idler load spring and rewind roller.

### 6. SUPPLY REEL SHAFT ASSEMBLY ADJUSTMENT

Felt clutch material is used between the lower side of the reel table base plate and the rewind rubber ring to protect recording tape from excessive tension during rewind operation. To check the amount of friction of this part, place onto the supply reel table a 5-inch reel with a 60 m/m diameter tape, and gently pull the end of tape upward with spring scale. Adjust the conical spring so that the amount of tension is kept between 400 and 500 grams. Other felt clutch material is attached to the rewind drive wheel to provide proper slippage during record or play operation. The procedure for checking friction of this part is the same as the foregoing, and between 100 and 125 grams of friction gives best results. When the unit is set to fast forward operation, the amount of friction will decrease to from 15 to 20 grams. Check to see whether this is correct. If not, readjust coil spring and spring retainer washer. (See figure 1 (a) at left)



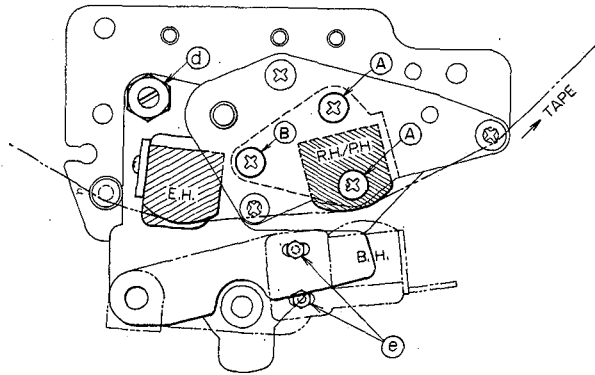

Fig. 2

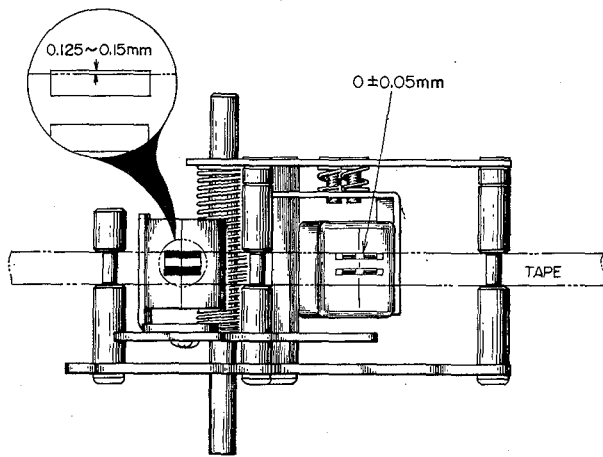

Fig. 3

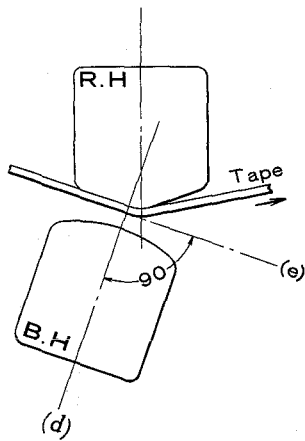

Fig. 4

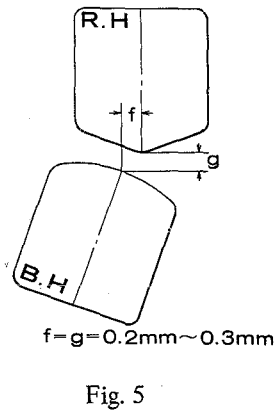

Fig. 5

## 7. HEAD ADJUSTMENT

### (A) Reel

- a) Azimuth alignment of the Recording/Playback Head (See Fig. 2)  
Playback an Ampex Alignment Tape (8,000 Hz) at a tape speed of 7-1/2 ips and turn screw (a) until the Line Out-Put Level reaches Maximum.
- b) Recording/Playback Head Height Alignment (See Fig. 2 and 3)  
Adjust head height by turning screws (b) and (c).
- c) Angle of Bias Head (See Fig. 2 and 4)  
Unfasten the two Bias screws and move the Bias Head by hand until the center line (d) of the Bias Head and the tape is at a 90° angle. Fasten screws.
- d) Clearance of the Bias Head (See Fig. 5)  
Unfasten the two Bias Head screws and move the Bias Head by hand until the clearance (f) and (g) reaches 0.2 to 0.3 mm. Then fasten screws.

Note : If the clearance (f) and (g) becomes less than 0.2 to 0.3 mm, the Frequency Characteristic will be too low, but Distortion will decrease. If the clearance (f) and (g) becomes more than 0.2 to 0.3 mm, the Frequency Characteristic will be too high, but Distortion will increase.

(B) Cartridge (See Figs. 6 and 7)

1) ADJUSTMENT OF AZIMUTH ALIGNMENT

Playback an azimuth alignment Test Tape (8,000 Hz recorded tape) and set the azimuth alignment of head assembly by turning screw (c) until maximum playback output of program 2 or 3 is obtained.

2) HEIGHT ADJUSTMENT

A) Playback \*a test tape and turn screw (d) until maximum gain of program 1 is obtained.

B) Set \*a blank test tape to recorder make a recording, and then make an erasing test. If erasing is not complete, adjust as follows :

(I) Turn screws (a) and (b) clockwise simultaneously forty-five degrees and then make erasing test again.

Note: The blank test tape should be demagnetized every time an erasing test is made.

(II) If the erasing is not complete after the above adjustment, turn screws (a) and (b) clockwise again ten to fifteen degrees simultaneously.

(III) If erasing is still not complete, repeat step 2) until complete erasing is accomplished. Playback Azimuth Alignment test tape again and turn screw (c) until maximum program gain of program 2 or 3 is obtained.

(IV) Playback test tape again and turn screw (d) until maximum gain of program 1 is obtained.

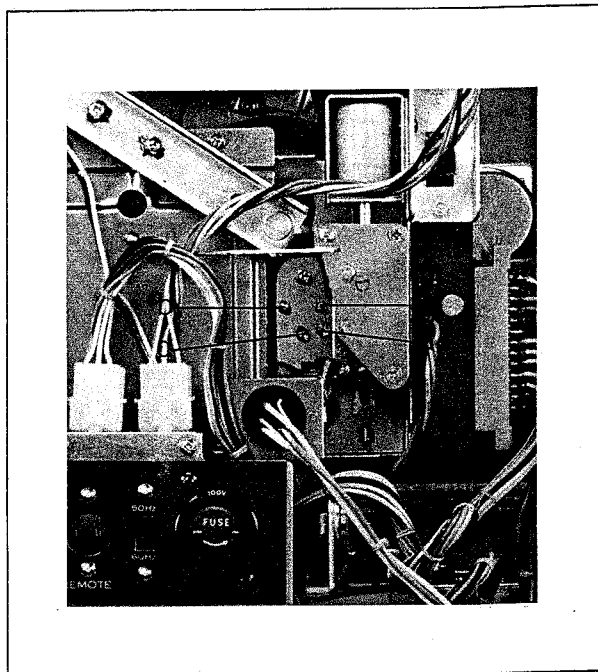

Fig. 6

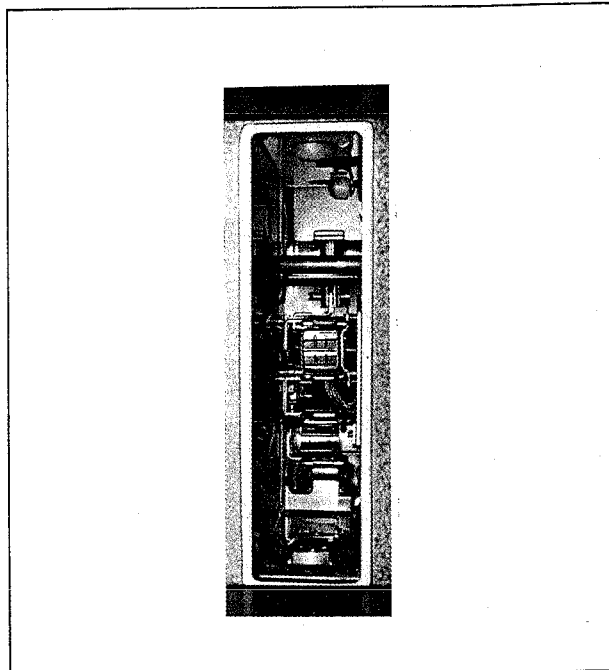

Fig. 7

(C) Cassette (See Fig. 8)

1) Playback a test tape (10 kHz) at a tape speed of  $1\frac{7}{8}$  ips and turn screw (a) until Line Output Level reaches maximum.

\* TEST TAPE

This test tape is specially designed by AKAI Height Adjustment tests.

Program 1 .....	1,000 Hz
Program 2 .....	Blank
Program 3 .....	1,000 Hz
Program 4 .....	3,000 Hz

\* BLANK TEST TAPE

This is also a special tape designed by AKAI. Duration of tape is only 15 seconds.

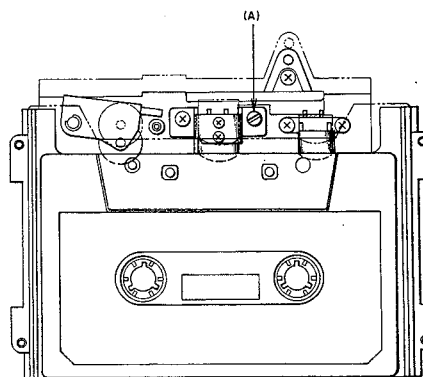

Fig. 8

# 8. CASSETTE BLOCK AND SELECTOR KNOB ADJUSTMENT

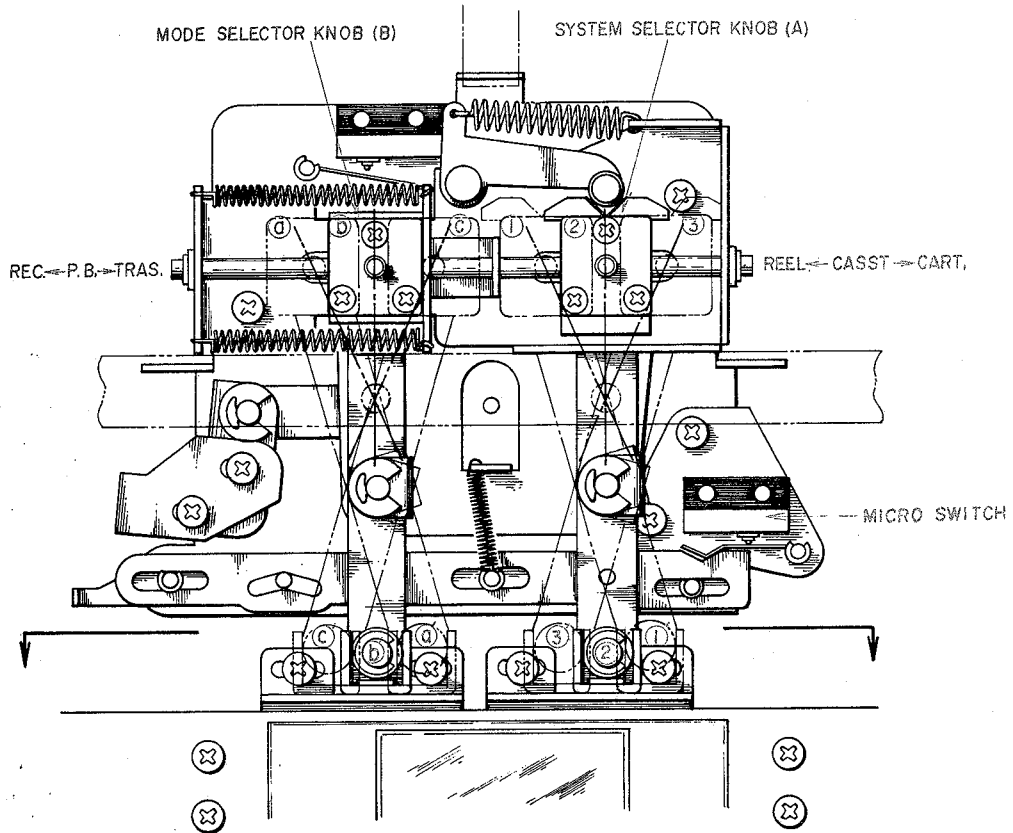

Fig. 9 (A)

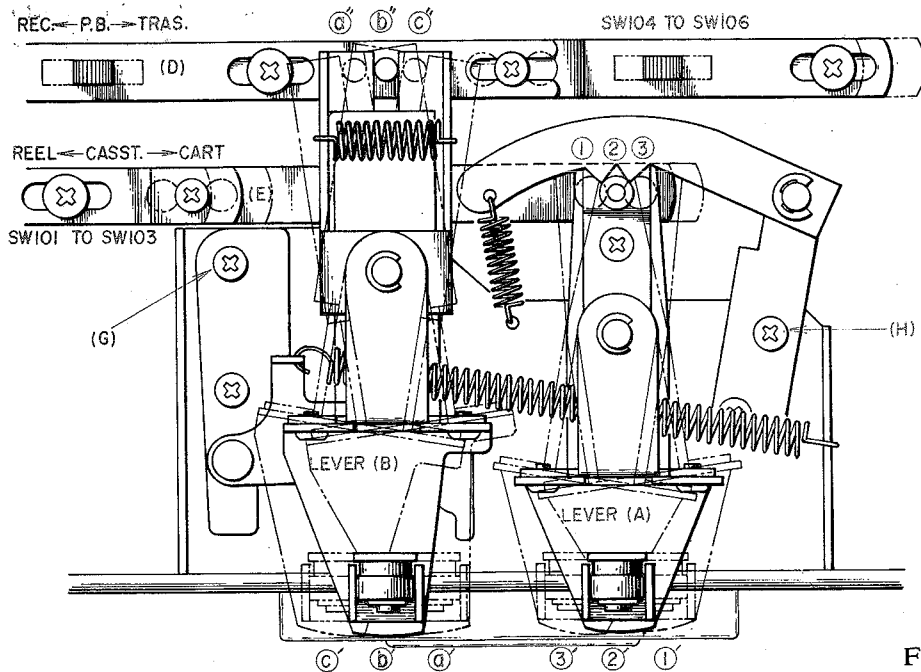

Fig. 9 (B)

(1) RECORDING, PLAYBACK, AND TRANSFER MECHANISMS (SEE FIG. 9 (A) (B) )

(A) Operation of RECORD/PLAYBACK/TRANSFER Changing Mechanism

When MODE SELECTOR KNOB (B) is set to Record position (a), Playback position (b), or Transfer position (c) (Fig. 1), Knob (B) actuates Switch Lever (D) to (a''), (b''), or (c'') position respectively and SW104, 105, or 106 is set to Record, Playback, or Transfer position.

(B) Adjustment Procedure

- a) Remove amplifier from chassis (leave wires between amplifier and chassis connected).
- b) Play back a 250 Hz or a 1000 Hz frequency cartridge or cassette tape (not a reel tape). Turn up volume so that both VU Meters indicate 0 VU.
- c) Return Mode Selector Knob (B) very slowly from Transfer Position (c) to Playback position (b). Just as Knob (B) is returning perfectly to position (b) (about 1/2 mm before perfected position), both VU Meters should indicate 0 VU and sound should come from speakers.
- d) Similarly, when Knob (B) is returned from position (a) to position (b) in the same way, both VU Meters should indicate 0 VU and speakers should emit sound instantaneously.
- e) In case the operation in items c) and d) above are not identical, loosen screw (G) and adjust the position of Knob (B).
- f) If this adjustment is not correct, sometimes recording or playback cannot be accomplished, or the operation of one channel is faulty.

(2) REEL/CASSETTE/CARTRIDGE SWITCH CHANGING MECHANISM (See Fig. 9 (A) (B) )

(A) Operation of Switch Changing Mechanism  
When System Selector Knob (A) is set to Reel position (1), Cassette position (2), or Cartridge position (3), (Fig. 1), Knob (A) actuates Switch Lever (E) to (1''), (2''), or (3'') position respectively, and SW-101, 102, or 103 is set to Reel, Cassette, or Cartridge position.

(B) Adjustment Procedure

- a) After adjustment (1) has been completed, place a pre-recorded reel, cassette, and cartridge tape on recorder for playback. Turn Lever (A) to each of the (1'), (2'), and (3') positions and confirm that playback is effected respectively.
- b) Return Knob (A) very slowly from (1') (Reel position), to (2') (Cassette position). Just as the lever is returning perfectly to (2') position (about 1/2 mm before perfected position), the sound from reel playback should be completely cut and playback of cassette only should be effected.
- c) Similarly, when Knob (A) is returned from (3') position to (2') position, the cartridge sound should be completely cut and playback of cassette only should be effected.
- d) If playback is not effected as outlined in items b) and c) above, loosen screw (H) and adjust the position of Knob (A).
- e) Confirm that the microswitch operates when Knob (A) is switched to positions (1'), (2'), and (3').

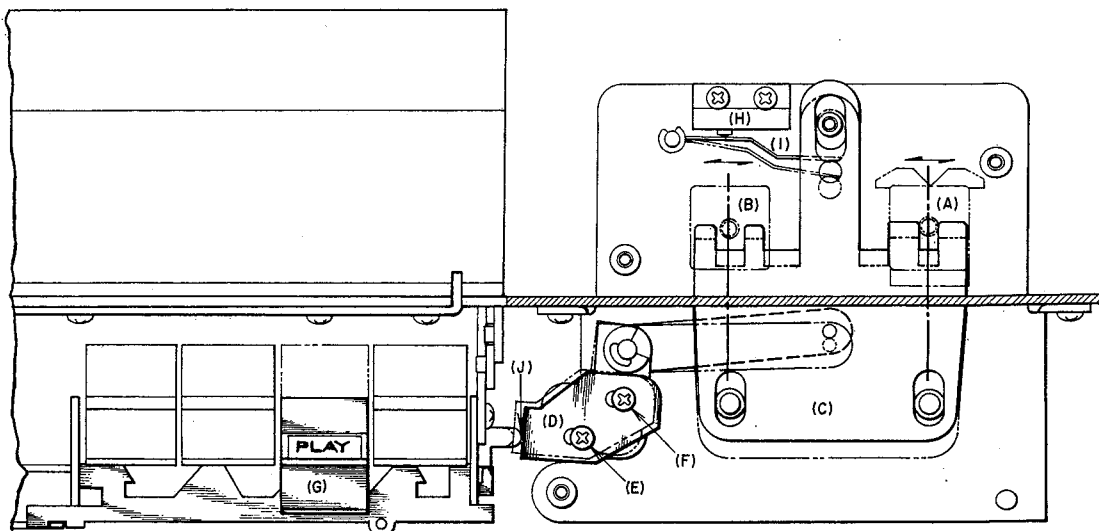

Fig. 10 (A)

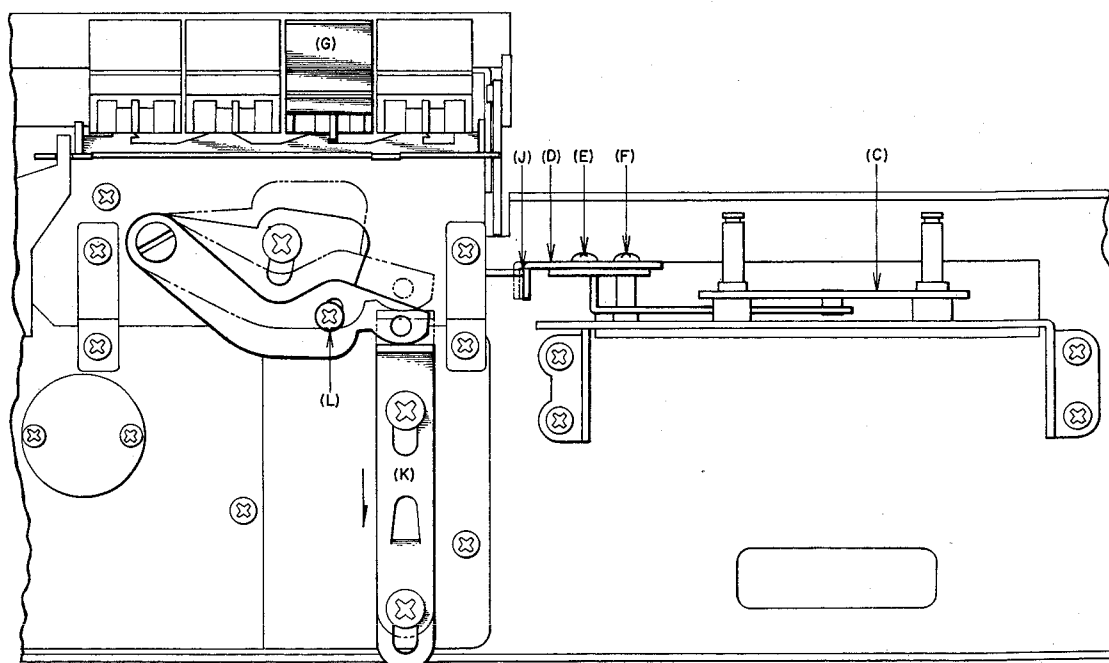

Fig. 10 (B)

(3) ADJUSTMENT OF KEYBOARD SELECTOR KNOBS PROTECTION DEVICE (See Fig. 10 (A) (B) )

Adjust screws (E,F) of Connecting Lever (D) so that at each keyboard operation (Play, F. Forward, and Rewind), SST Lever (C) moves until Slider (Selector Knob) A & B is perfectly locked into position. For example, as shown in the diagram, when Play Key (G) is depressed, Slider (A) (B) is locked into the groove of SST Lever (C) and does not move to the left or right.

Further, at this time, adjust Switch Mount position as well as the bend of Actuator (I) so that Microswitch (H) operates.

Caution : If Connecting Lever D is not greased at arrow mark (J), the operation of each Key will become heavy (will not operate easily).

(4) ADJUSTMENT OF PLAY KEY (See Fig. 10 (A) (B) )

At "Play" position, in order for the Head Plate to be perfectly pushed into position, (at this condition, cassette tape surface and head comes in ideal contact) with Operation Lever (K) depressed fully toward direction of arrow mark, mount screw (L) so that Play Key (G) is locked. (At this time, when Play Key is depressed, Operation Lever (K) should have no more than a 0.5 mm movement leeway).

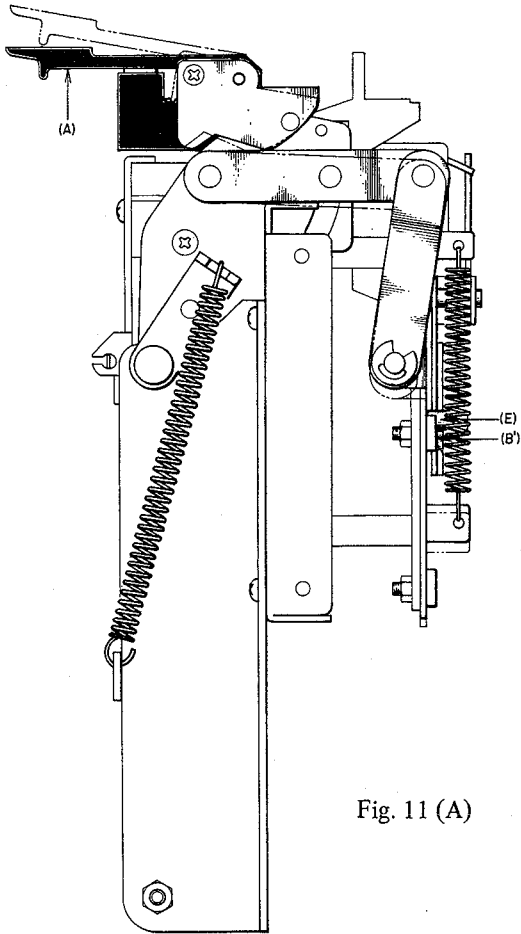

Fig. 11 (A)

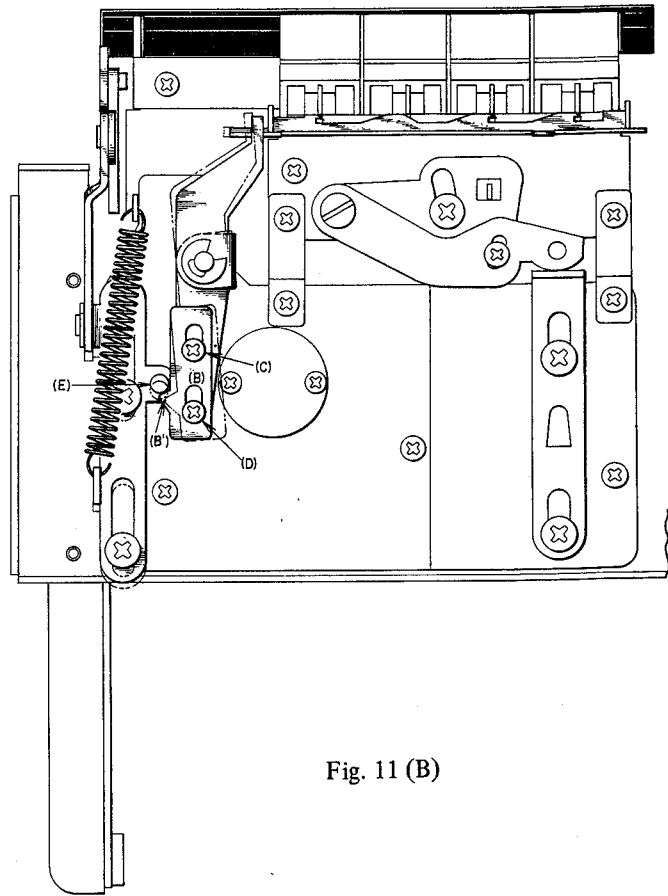

Fig. 11 (B)

(5) ADJUSTMENT OF CASSETTE COVER KEY-BOARD PROTECTION DEVICE (See Fig. 11 (A) (B) )

During operation of each key (Play, F. Forward, and Rewind), adjust screws (C and D) so that the Key Lock is released when the cassette cover is opened. Open Cover (A) and without depressing Key, fix screws (C and D) until the projected part of Lever (B) comes in contact with Pin (E).



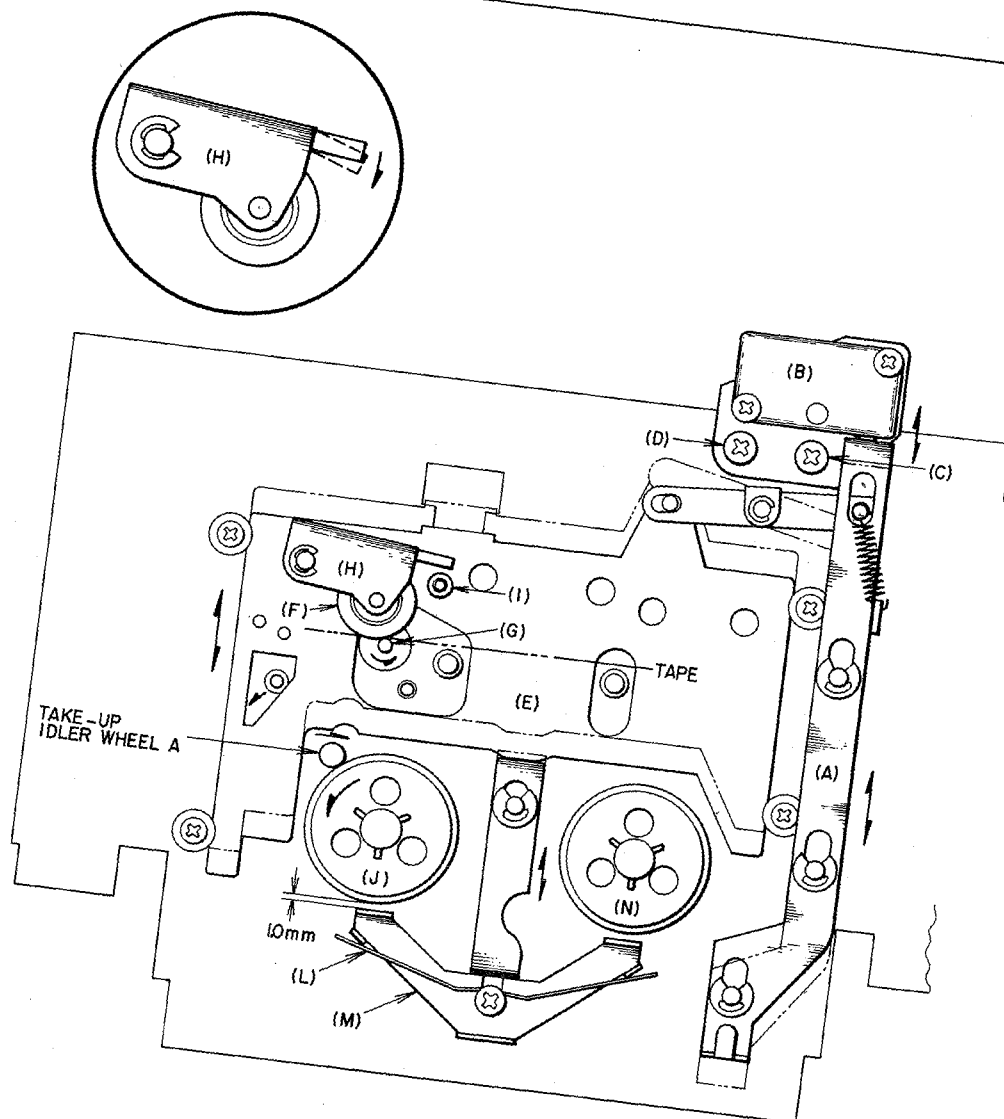

Fig. 12

**(6) ADJUSTMENT OF RECORDING PROTECTION DEVICE (See Fig. 12)**

At "Play" position, after Recording Safety Lever (A) has slid into perfect position, adjust screws (C and D) so that Microswitch (B) functions properly. When recording is stopped, confirm that Microswitch (B) releases Lever (A).

**(7) ADJUSTMENT OF PINCH WHEEL PRESSURE TIMING (See Fig. 12)**

When Play Key is depressed for playback, Head Plate (E) moves in the direction of the arrow mark, Pinch Wheel (F) presses against Capstan (G), and Pinch Wheel Lever (H) is released from Stopper Pin (I).

At this time, Reel Table (J) is already rotating. In case Pinch Wheel (F) rotates before Reel Table (J), bend the part of Pinch Wheel Lever (H) which contacts Stopper Pin (I) toward arrow mark to slow pinch wheel pressure timing so that the Reel Table rotates first.

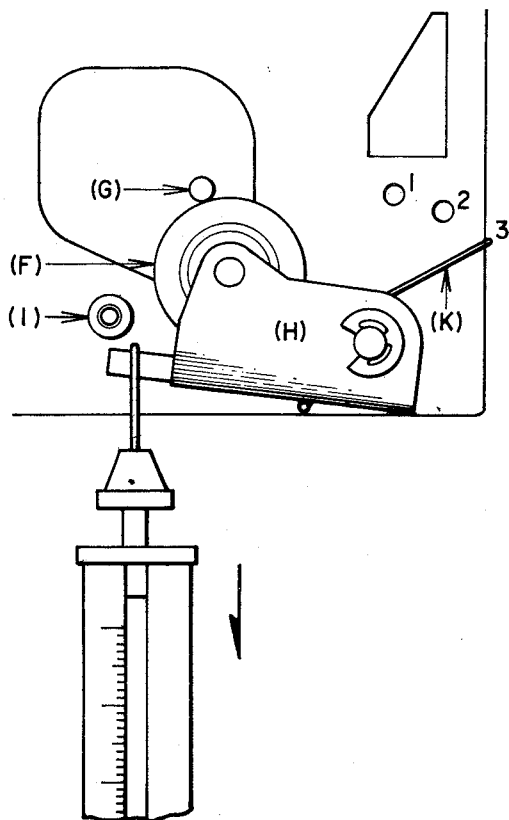

Fig. 13

**(8) PINCH WHEEL PRESSURE STRENGTH ADJUSTMENT (See Figs. 12 and 13)**

At Play Mode, when Pinch Wheel (F) is pressed against Capstan (G), as shown in diagram, connect a Spring Gauge and pull in direction of arrow. Adjust movement of Spring (K) at adjustment holes 1, 2, and 3 so that when Pinch Wheel (F) is released from Capstan (G), the Spring Gauge value is from 180 to 230 grams. In the same way, at Stop Mode, when Pinch Wheel Lever (H) is released from Stopper Pin (I), a Spring Gauge value of about 100 to 150 grams is ideal.

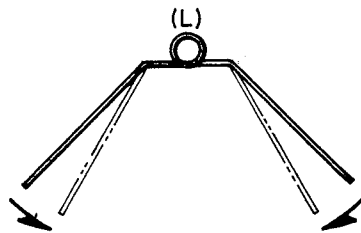

Fig. 14

**(9) BRAKE ADJUSTMENT (See Figs. 12 and 14)**

If operation of brake is weak when stopped from Play, Fast Forward and Rewind Mode, strengthen by bending Brake Spring (L) in direction of arrow. Further, during Play, Fast Forward, and Rewind Mode, Brake Lever (M) must be separated from the rubber surface of left and right reel table by more than 1.0 mm.

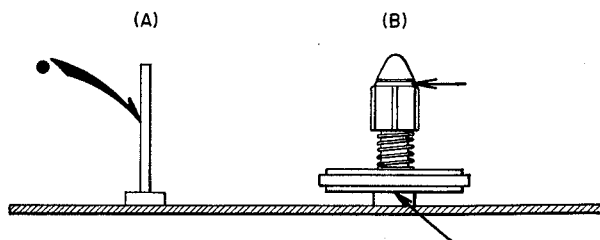

Fig. 15

**(10) REEL TABLE ADJUSTMENT (See Fig. 15)**

With Brake Lever separated from Reel Table, when Reel Table is rotated by hand, if an abnormal sound is produced, apply an exceedingly small amount of oil to Reel Shaft (A).

Or, if Reel Table does not rotate smoothly, Cap (B) is putting pressure on Reel Table.

Further, if Reel Table moves up and down too excessively, adjust by inserting a washer at top and bottom of Reel Table (at arrow).

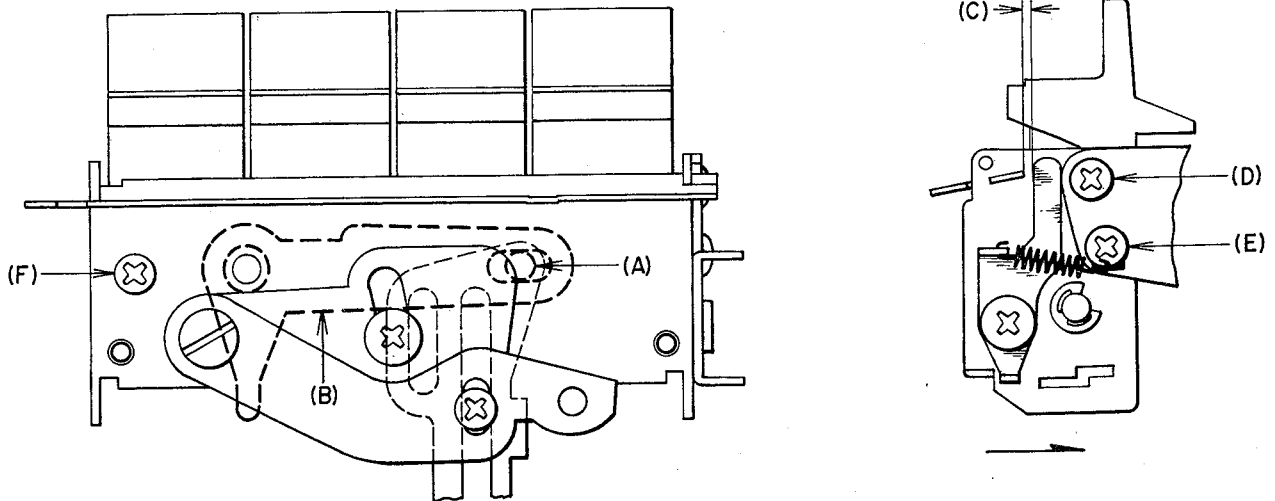

Fig. 16

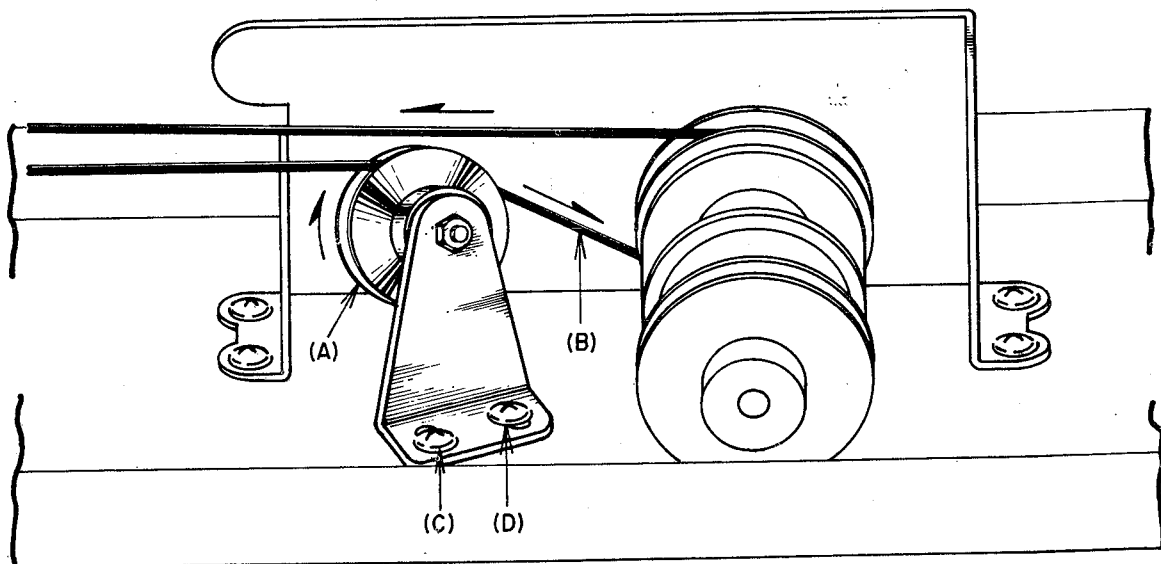

Fig. 17

(11) MOUNTING KEYBOARD BLOCK (See Fig. 16)

When mounting Keyboard Block on Cassette Block, insert Take-Up Lever (A) in hole and while holding in position toward arrow, fix mounting screws (D, E, and F) so that gap (C) is open.

(12) ADJUSTMENT OF BELT DRIVE CENTER PULLEY (See Fig. 17)

If main motor is caused to rotate, adjust screws (C and D) so that Belt (B) of Center Pulley (A) does not twist or come up to side or top part of Pulley (A) (Belt (B) should run smoothly in center groove of Pulley (A)).

## VII. AMPLIFIER ADJUSTMENT

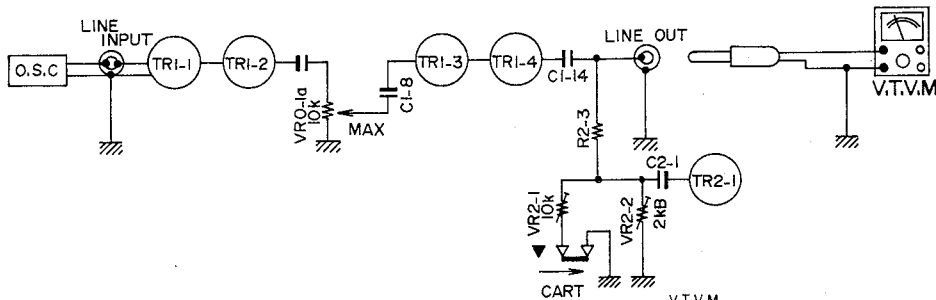

Fig. 1

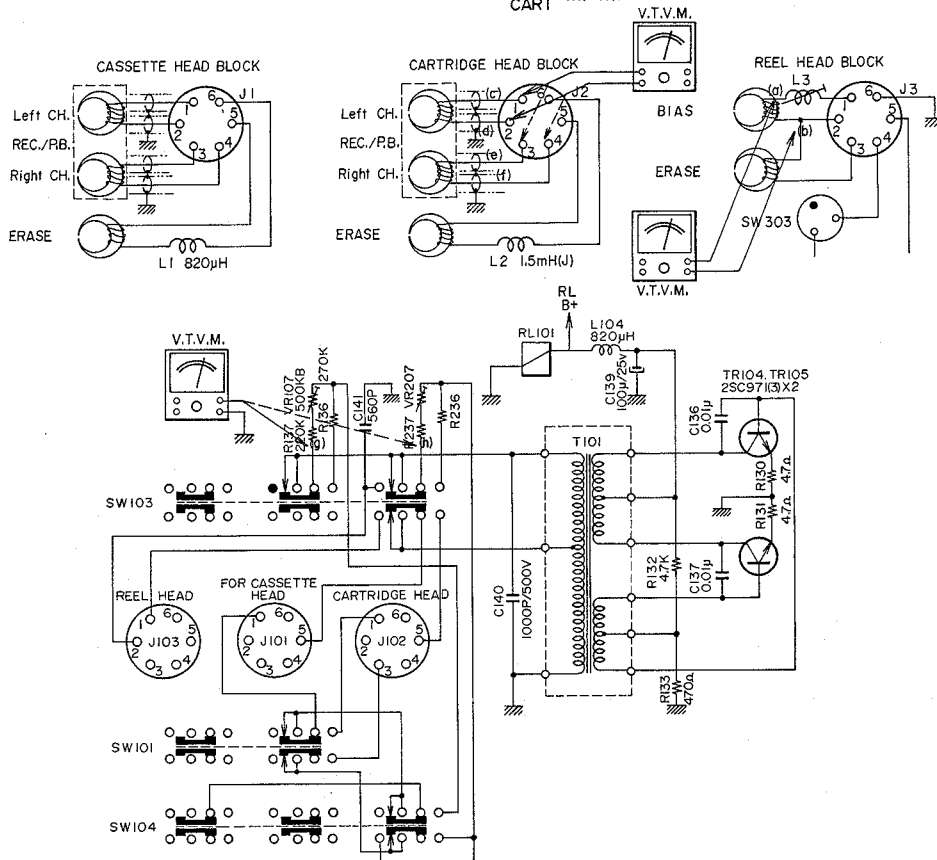

Fig. 2

### 1. ADJUSTMENT OF RECORDING BIAS FREQUENCY (See Fig. 1)

- Put on the resistor 10 or 50 Ohms in series with the Bias Head and connect the Vertical Input Terminal of the Oscilloscope to points (a) and (b).
- Feed in a sine wave signal from an Audio Frequency Oscillator to the Horizontal Input of the Oscilloscope and tune the Dial of the Audio Frequency Oscillator until the Oscilloscope displays a circular or linear pattern. Then read the figure on the Dial of the Audio Frequency Oscillator.
- If it reads 80 kHz, the Recording Bias Frequency is correct.
- If not correct, it may be adjusted by inserting another condenser (C-140) value 1000 PF.

### 2. ADJUSTMENT OF RECORDING BIAS VOLTAGE

- Reel (See Fig. 2)  
Connect a V.T.V.M. to point (a) and (b) and adjust the recording bias voltage by turning L-3 in the bias oscillator circuit until it reads the same as the voltage stamped on the back of the head assembly.  
Note : There is no way of adjusting the erasing bias voltage, but the correct bias voltage is between AC 25 to 30 V.
- Cartridge (See Fig. 2)  
Connect a V.T.V.M. to point (b) and measure the Bias Voltage. Correct bias voltage is between AC 12 to 15 V. It can be adjusted by changing R (236) (136).
- Cassette (See Fig. 3)  
Connect a V.T.V.M. to point (g) or (h) and adjust the recording Bias Voltage by turning VR 207, VR 107, in the bias oscillator circuit. Proper bias voltage is about 11 V.

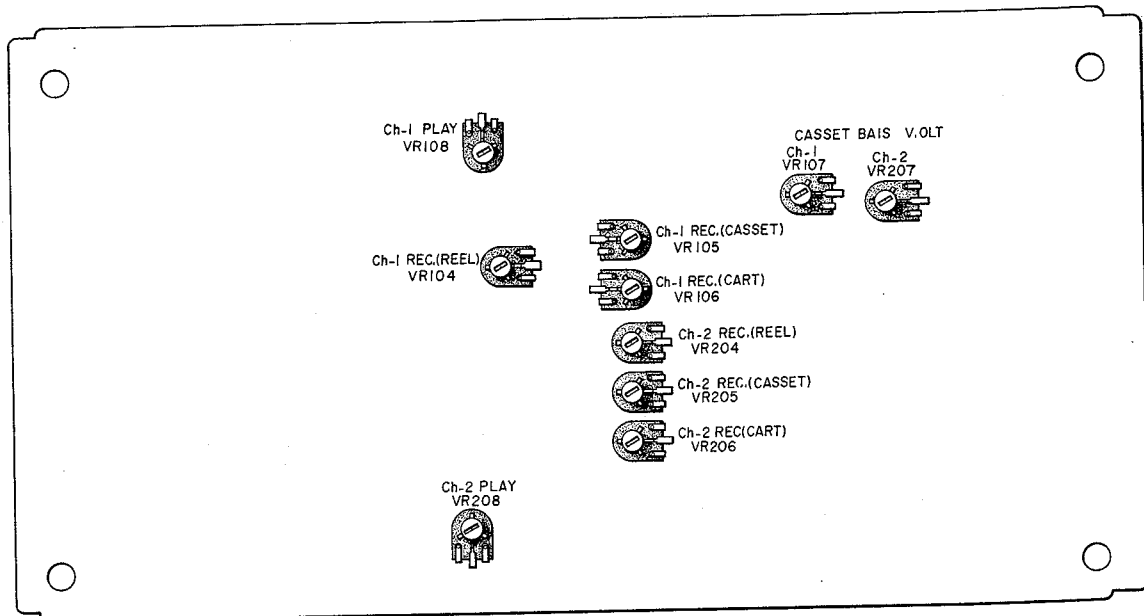

Fig. 3

### 3. ADJUSTMENT OF LINE OUTPUT LEVEL

#### (A) Playback Output Level (Pre-Amplifier Adjustment (REEL) (Ref. Fig. 3)

- a) Connect a high sensitivity V.T.V.M. to the Line Output Jack.
- b) Play back a 250 Hz pre-recorded tape at 7-1/2 ips.
- c) Adjust VR-108, and VR-208 (semi-fixed resistor 30 KB Fig. 3) of the pre-amplifier so that the Line Output Voltage is 1.228 V ( $\pm 4$  dB).

#### (B) Recording Level Adjustment

Recording amplifier adjustment should be made only after Head Adjustment (Vertical and Horizontal Azimuth) and Playback amplifier adjustments have been made.

##### 1) REEL

- a) As shown in Fig. 4, connect an Audio Signal Generator and Attenuator the Line Input. Connect a high sensitivity V.T.V.M. to the Line Output.

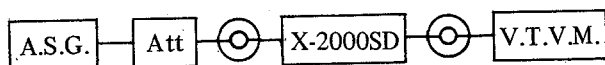

Fig. 4

- b) Set Equalizer Switch and Tape Speed Selector to "7-1/2". Load a blank test tape (Fuji FYS-100 or Scotch No. 150).
- c) Supply a 1000 Hz signal from the audio signal generator to the Line Input, and adjust each of the Volume Controls so that each of the VU Meters indicate "0" VU (intermediate between red and black).

- d) Record the signal on the tape and check playback to see whether VTVM. Meters Indicate +4 db.
- e) If VTVM. Meter indicator fails to register +4 db, repeat recording and playback by adjusting the semi-fixed resistors VR 104, or VR 204 (10 K $\Omega$  B semi-fixed resistor) until +4 db reading is obtained, both on recording and playback.

##### 2) CASSETTE

- a) Set recorder to Cassette Recording position and load a blank cassette tape.
- b) Follow steps c) through e) of reel procedure above (Adjust VR 105 and VR 205. Recorded signal output level is -1 to +2 dB).

##### 3) CARTRIDGE

- a) Set the recorder to Cartridge Recording position and load a blank cartridge tape.
- b) Follow steps c) through e) of reel procedure above (Adjust VR 106 and VR 206. Recorded signal output level is 0 + 2 dB).

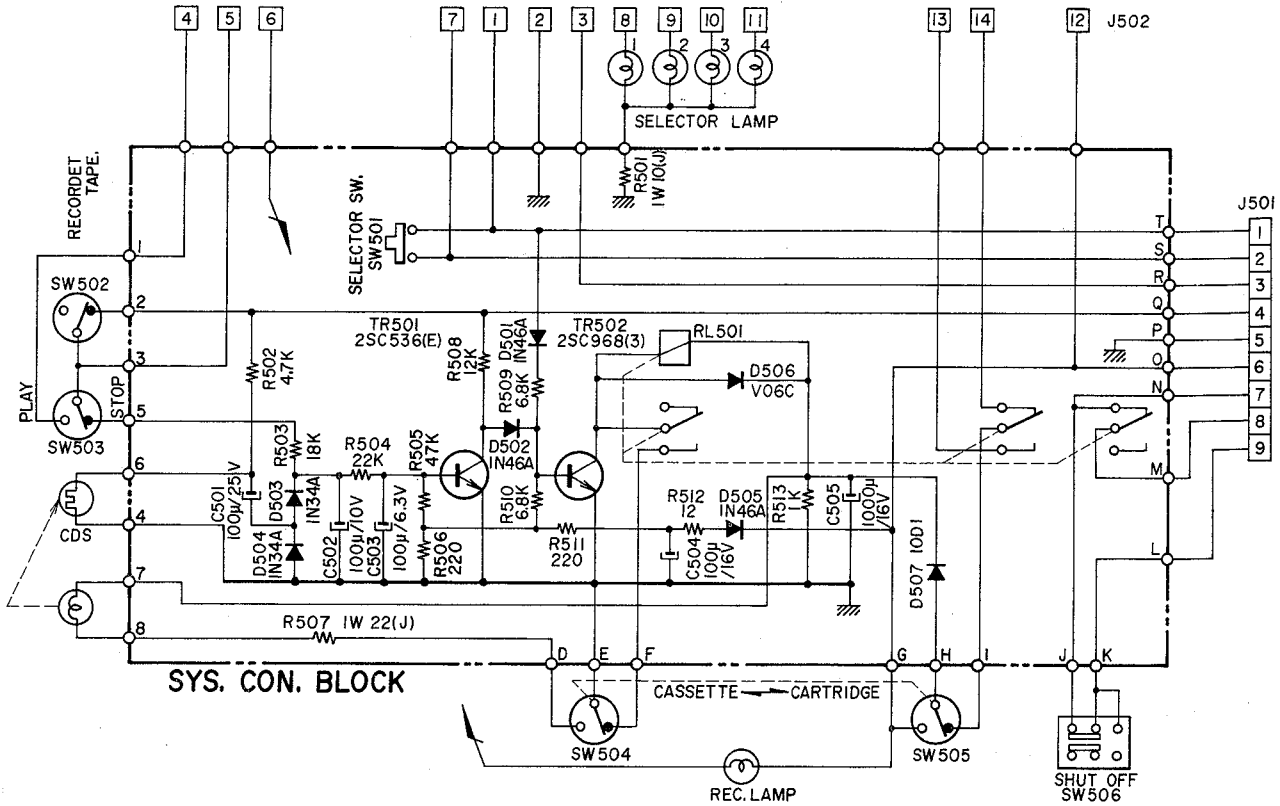

Fig. 5

#### 4. CASSETTE AUTO-STOP CIRCUIT OPERATING PRINCIPLE (SEE Fig. 5)

During tape movement, the tape passes over three holes in the reel table. As the tape passes over the holes, a light bulb (electric eye) located underneath the reel table is activated which causes C.D.S. to produce a pulse. TR-501 operates as long as this pulse continues, and TR-502 is inoperative as well as RL-501 Relay. When tape movement stops and reel revolutions are stopped, there is no pulse and the operation of TR-501 and TR-502 reverses. At this time, the relay is actuated and stops the motor.



## VIII. MAINTENANCE PROCEDURES

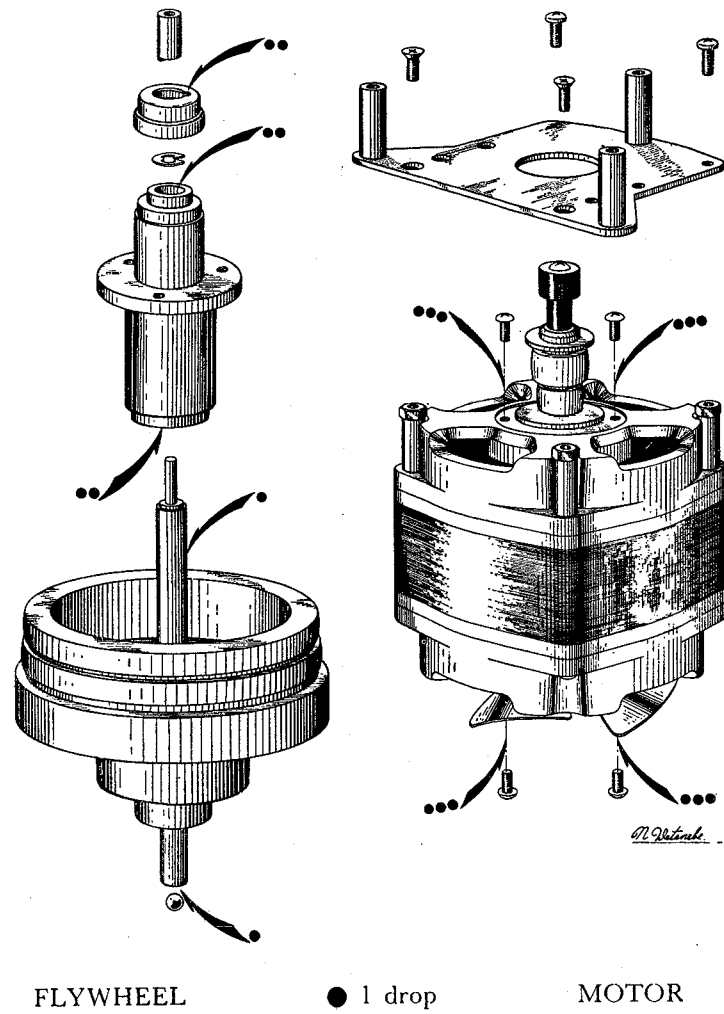

### 1. LUBRICATION INSTRUCTION

For maximum service life and optimum performance, lubricate the parts identified below after each 500 hours of operation. Use only light machine oil of good quality.

Motor

Flywheel Assembly

Rewind Idler Wheel and Wind Take-Up Idler 1 drop

Intermediate Idler 1 drop

Pinch Wheel 1 drop

Also apply a liberal film of light machine grease to each roller surface of all levers and cams.

**CAUTION : DO NOT OVER-LUBRICATE, AND WIPE OFF EXCESS OIL WITH A COTTON SWAB SOAKED IN ALCOHOL. OTHERWISE, THE EXCESS LUBRICANT MAY BE SCATTERED DURING OPERATION. AND THE RUBBER COMPONENT PARTS WILL DETERIORATE.**

### 2. CLEANING TAPE HEADS AND OTHER PARTS

Wipe surface of tape heads, guide roller bearing, capstan bushing and pinch wheel periodically with a soft cloth soaked in alcohol or carbon-tet.

# IX. COMPOSITE VIEWS OF COMPONENTS

PRE/MAIN AMPLIFIER P.C. BOARD (RCC-515)

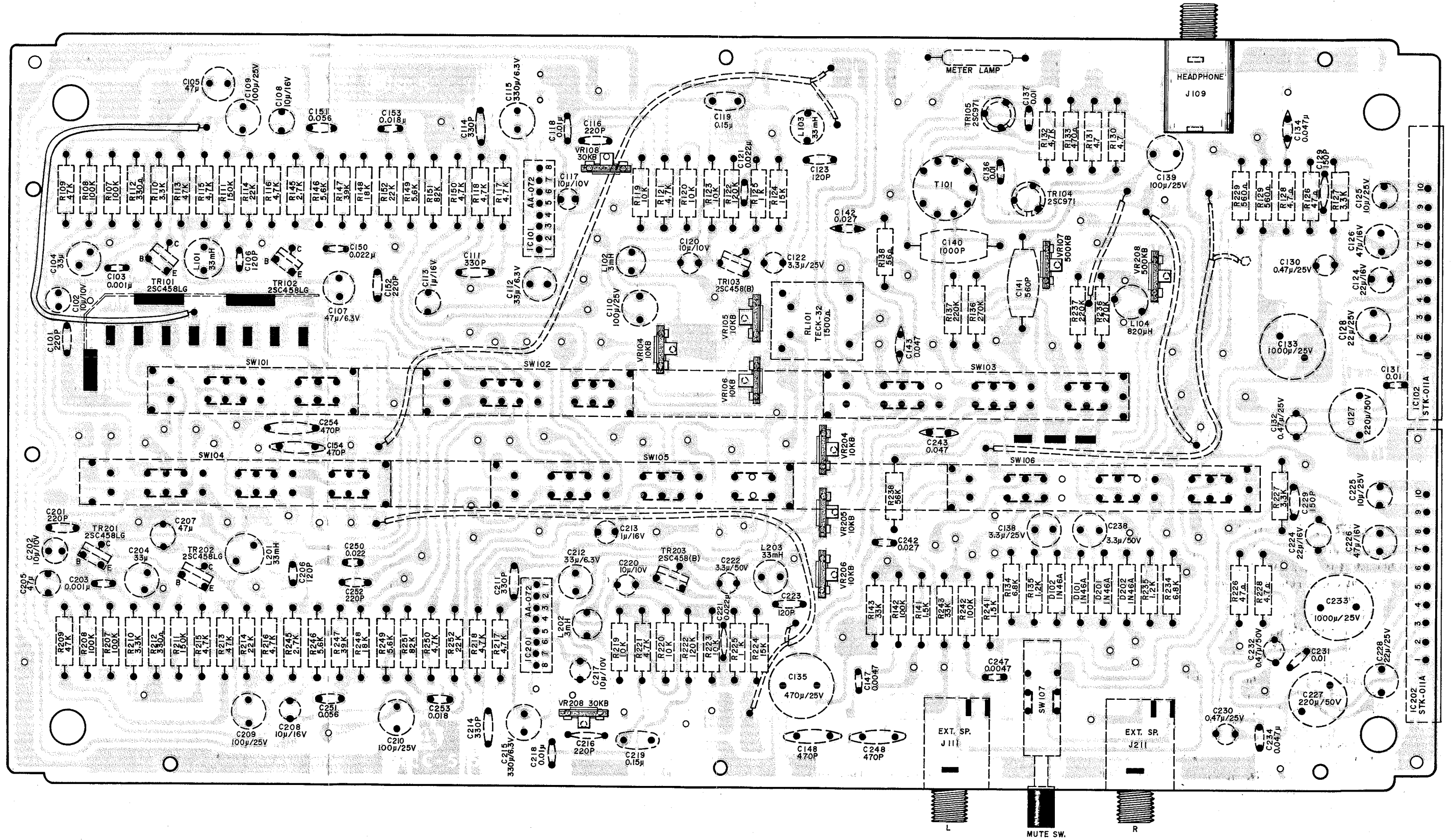

SYSTEM CONTROL P.C. BOARD (RCC-1501) SD

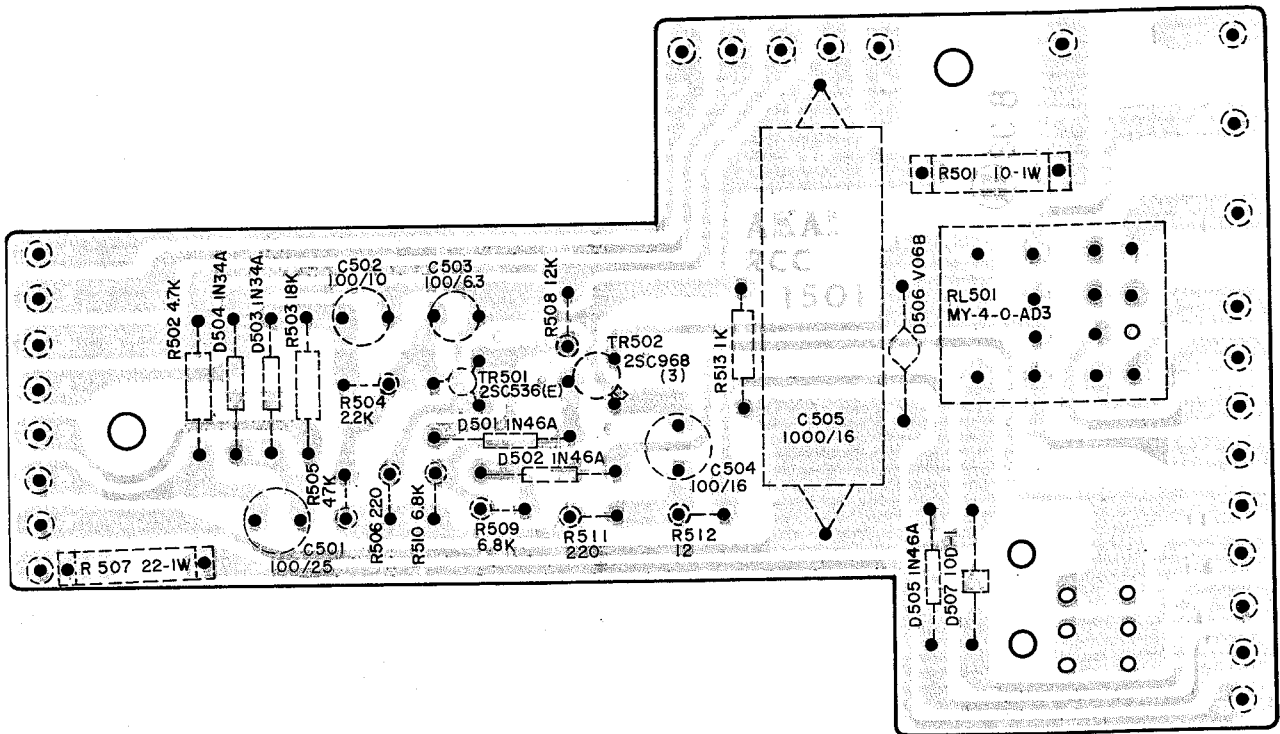

CARTRIDGE P.C. BOARD (RCC-306) SD

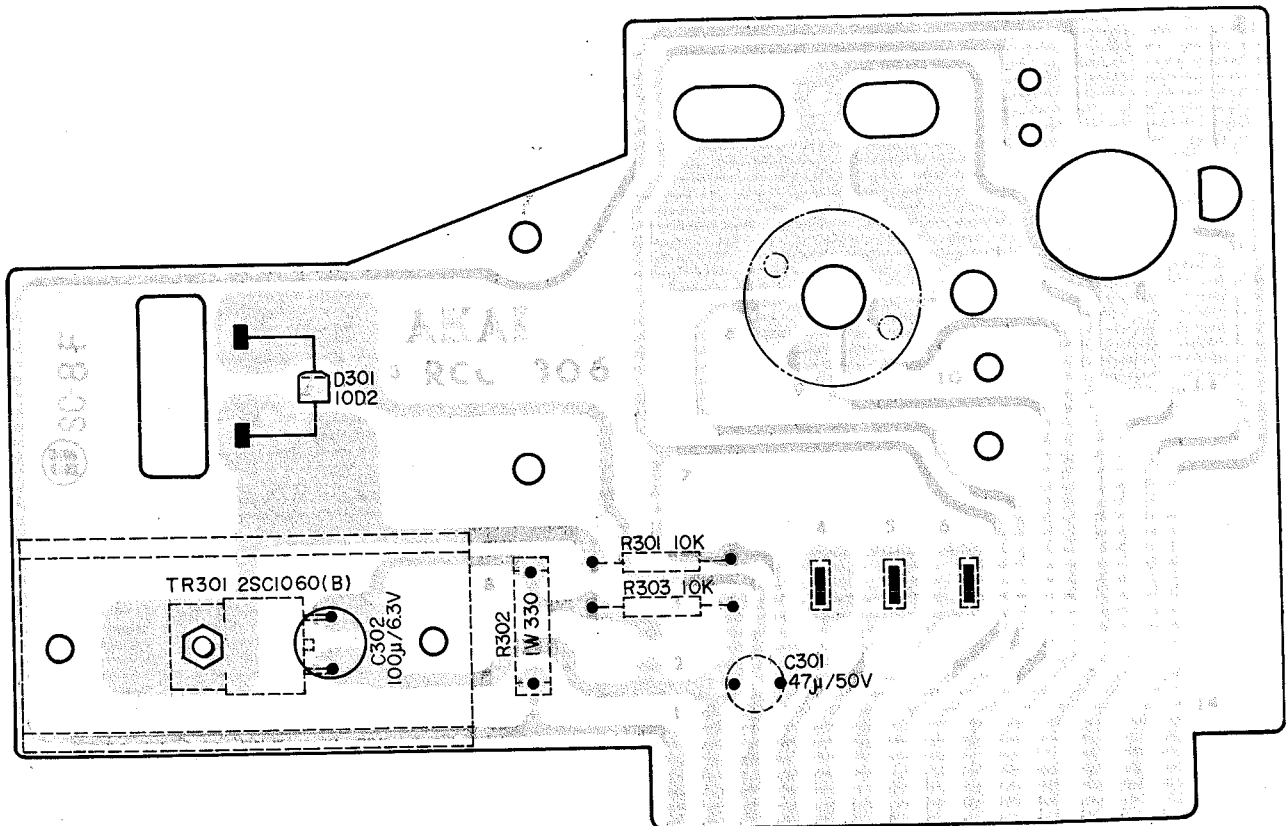

POWER SOURCE P.C. BOARD (RCC-542) SD

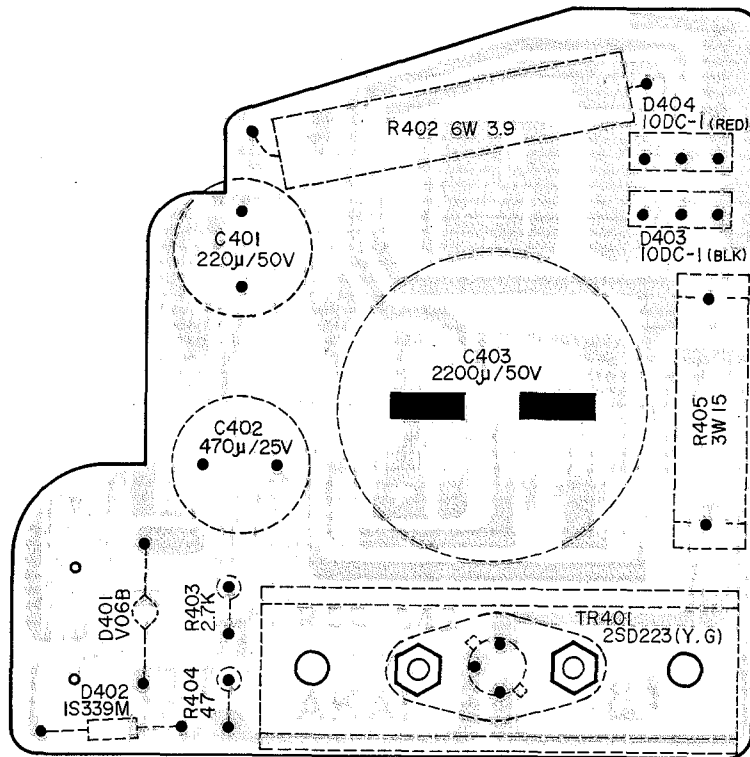

SYSTEM CONTROL P.C. BOARD (RCC-1509) S

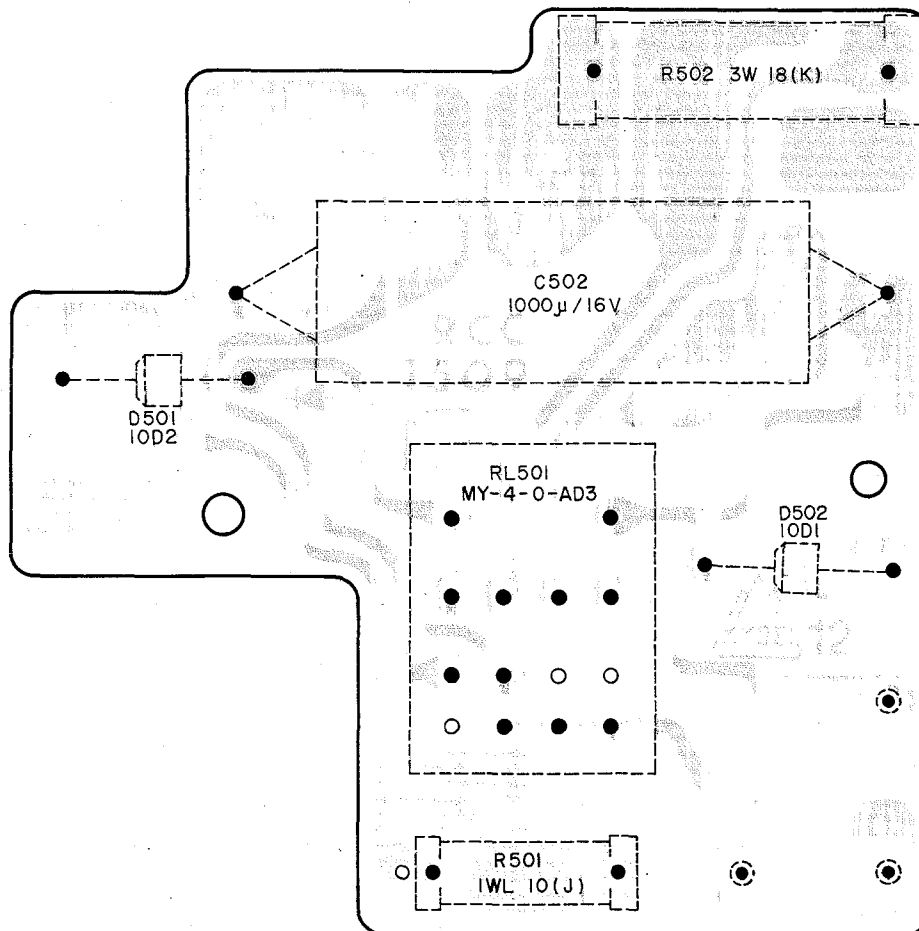

CARTRIDGE P.C. BOARD (RCC-308) S

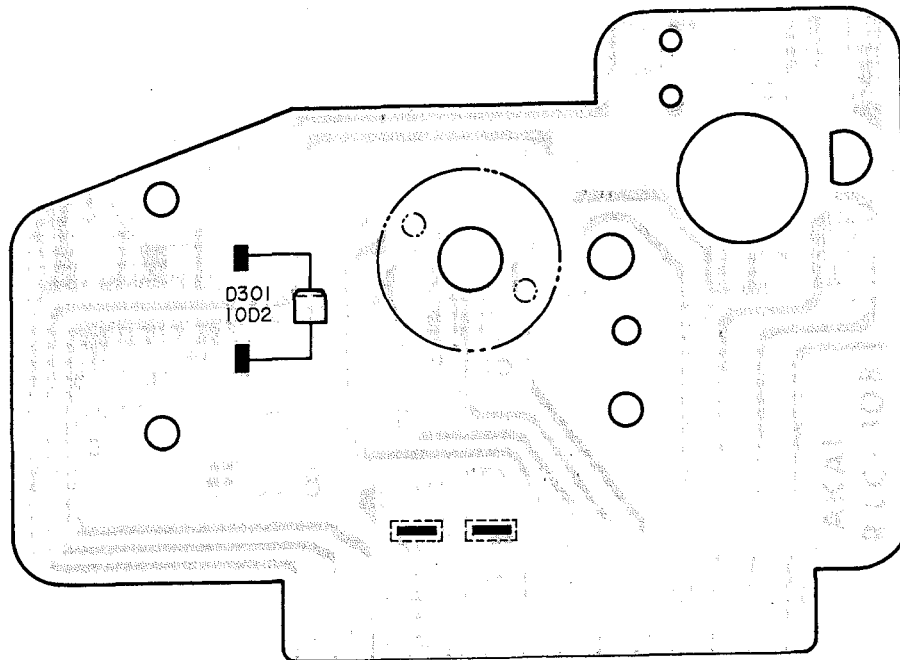

POWER SOURCE P.C. BOARD (RCC-1508) S

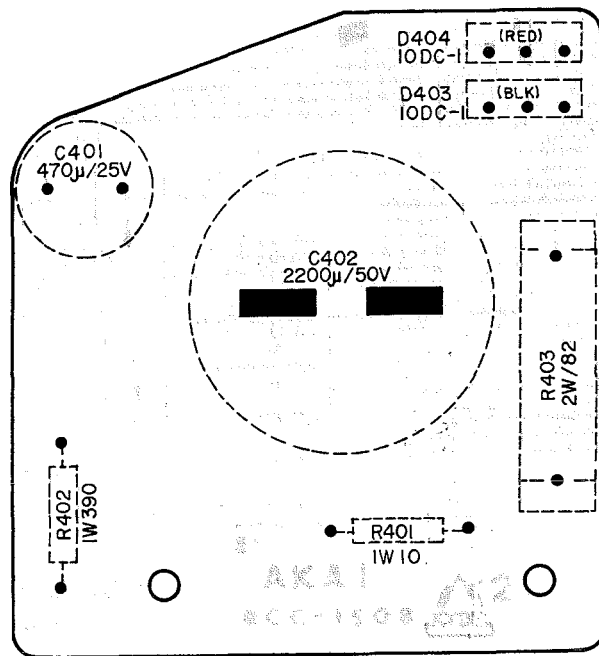

EQUALIZER P.C. BOARD (RCC-517)

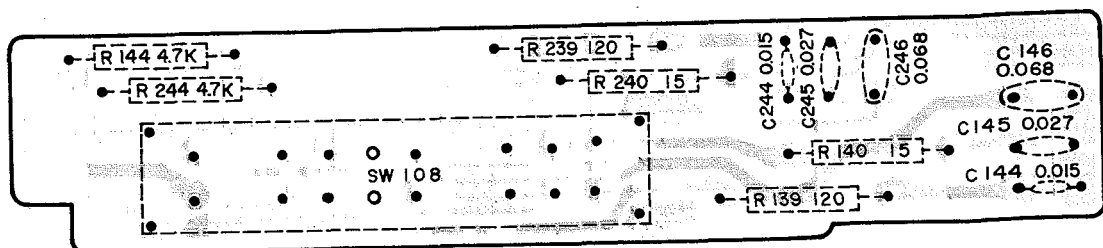

## 2. Recording problems.

(Unit plays back pre-recorded tapes okay, but recording not satisfactory.)

### a) Reel

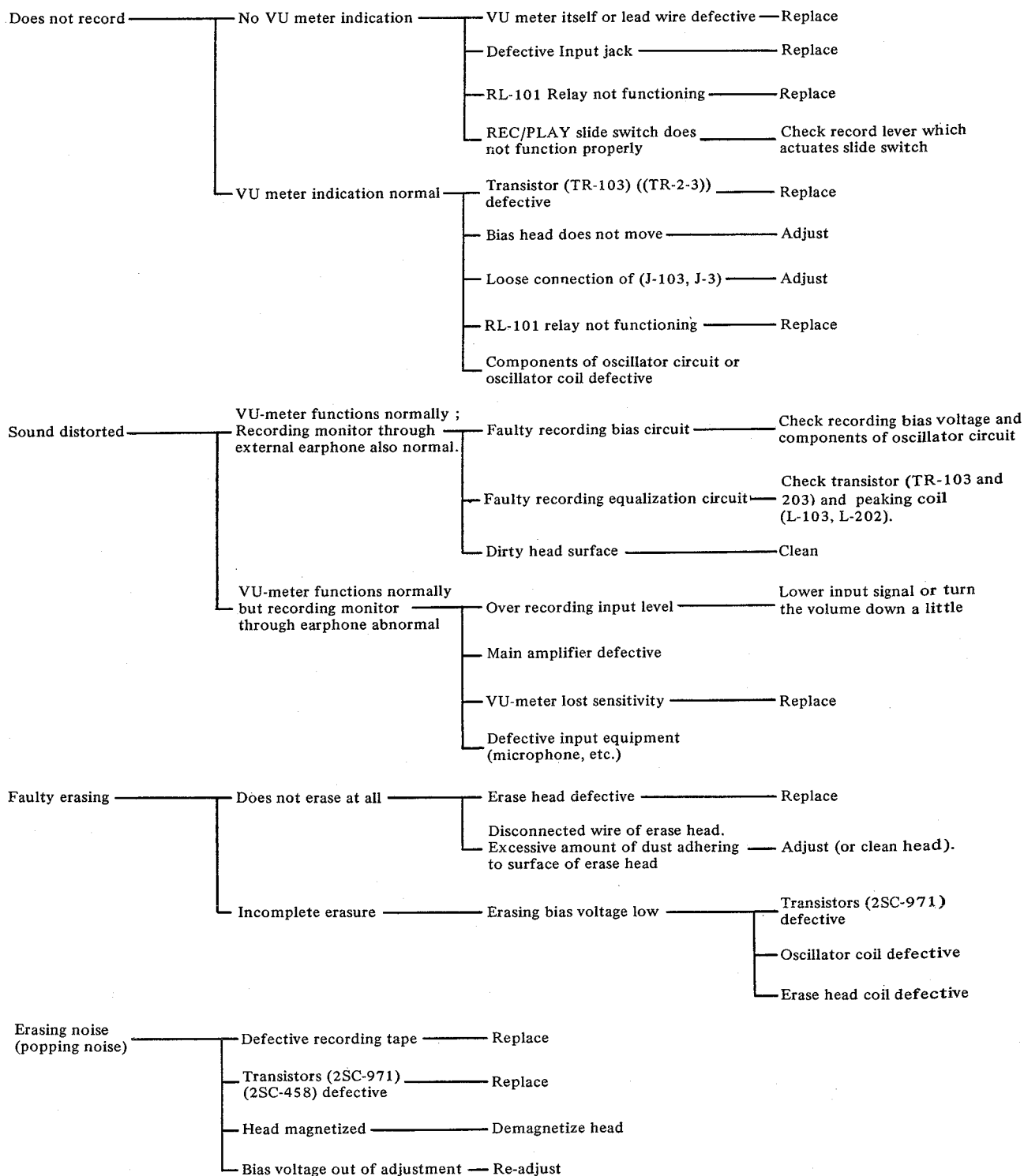



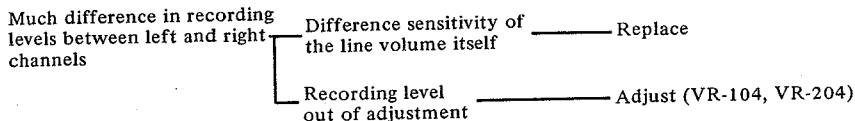
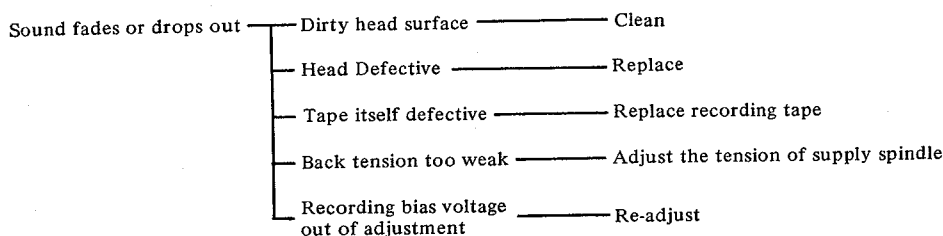
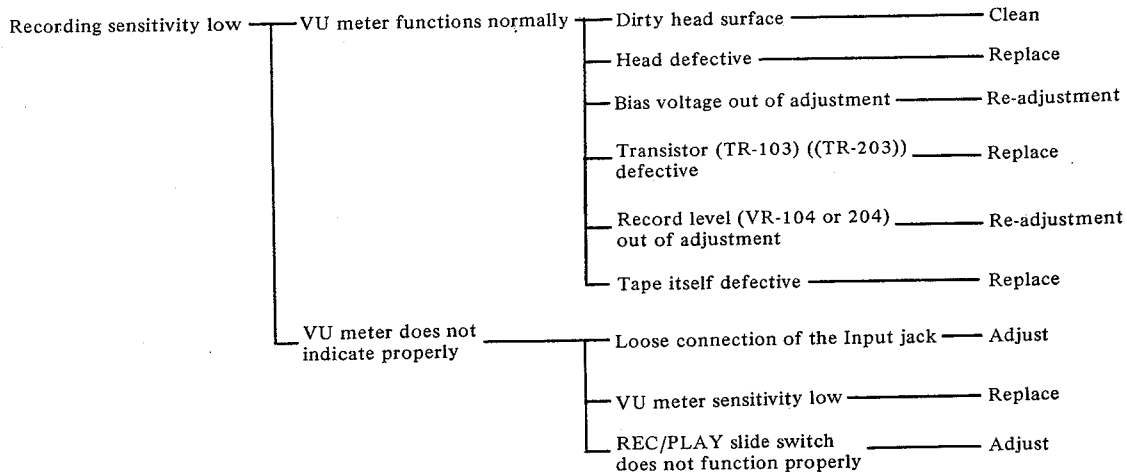

b) Cartridge/Cassette

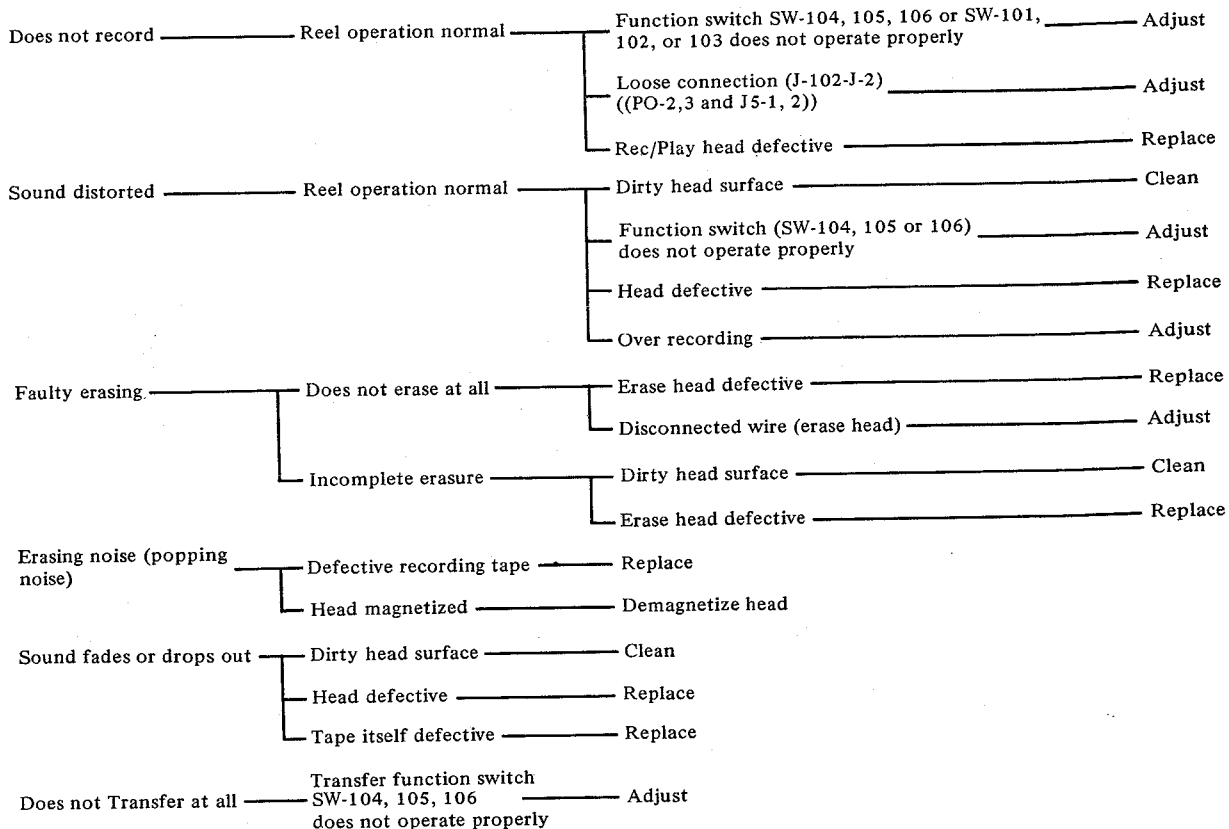

# SECTION "B" TROUBLES WITH TAPE TRANSPORT MECHANISM

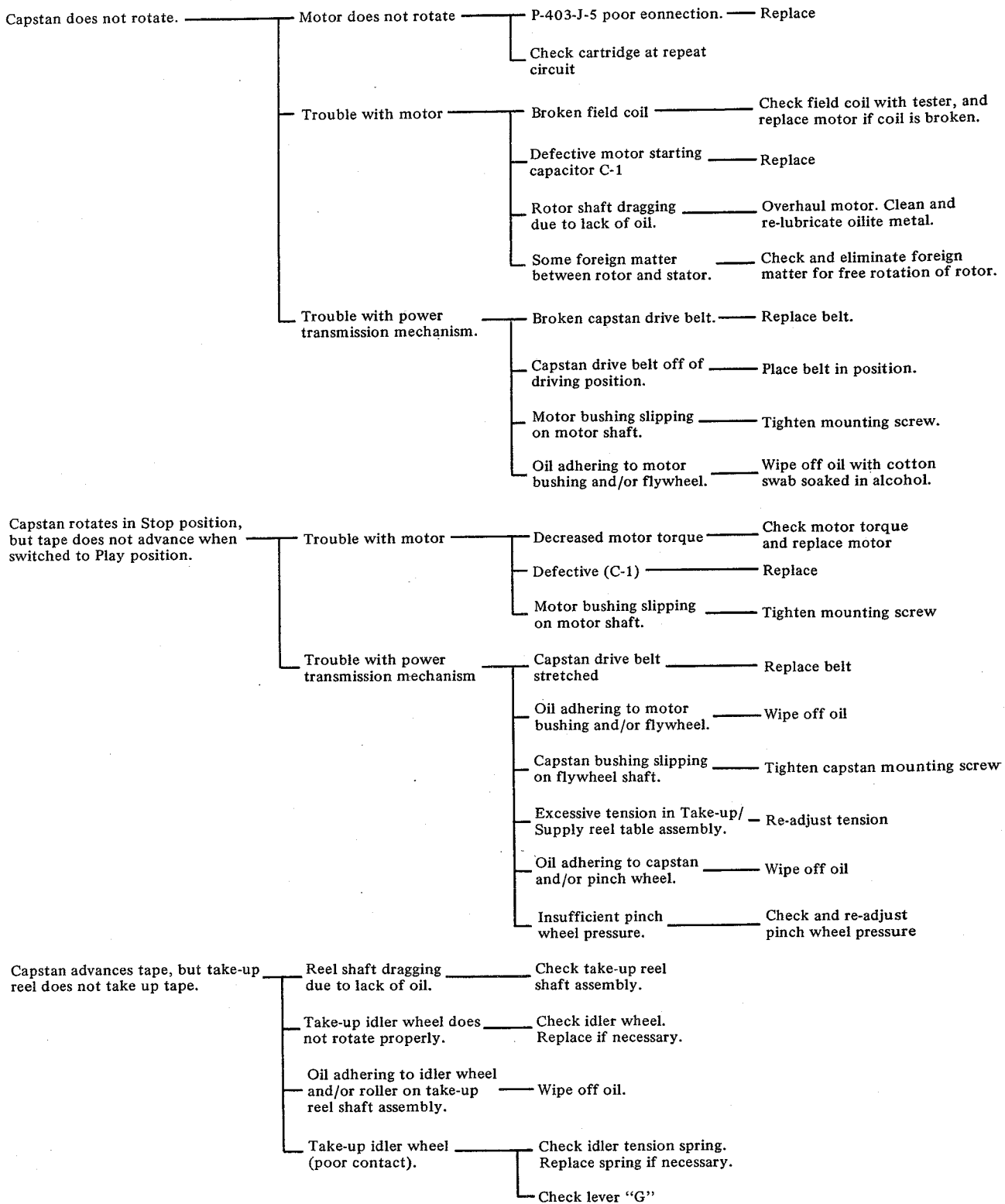

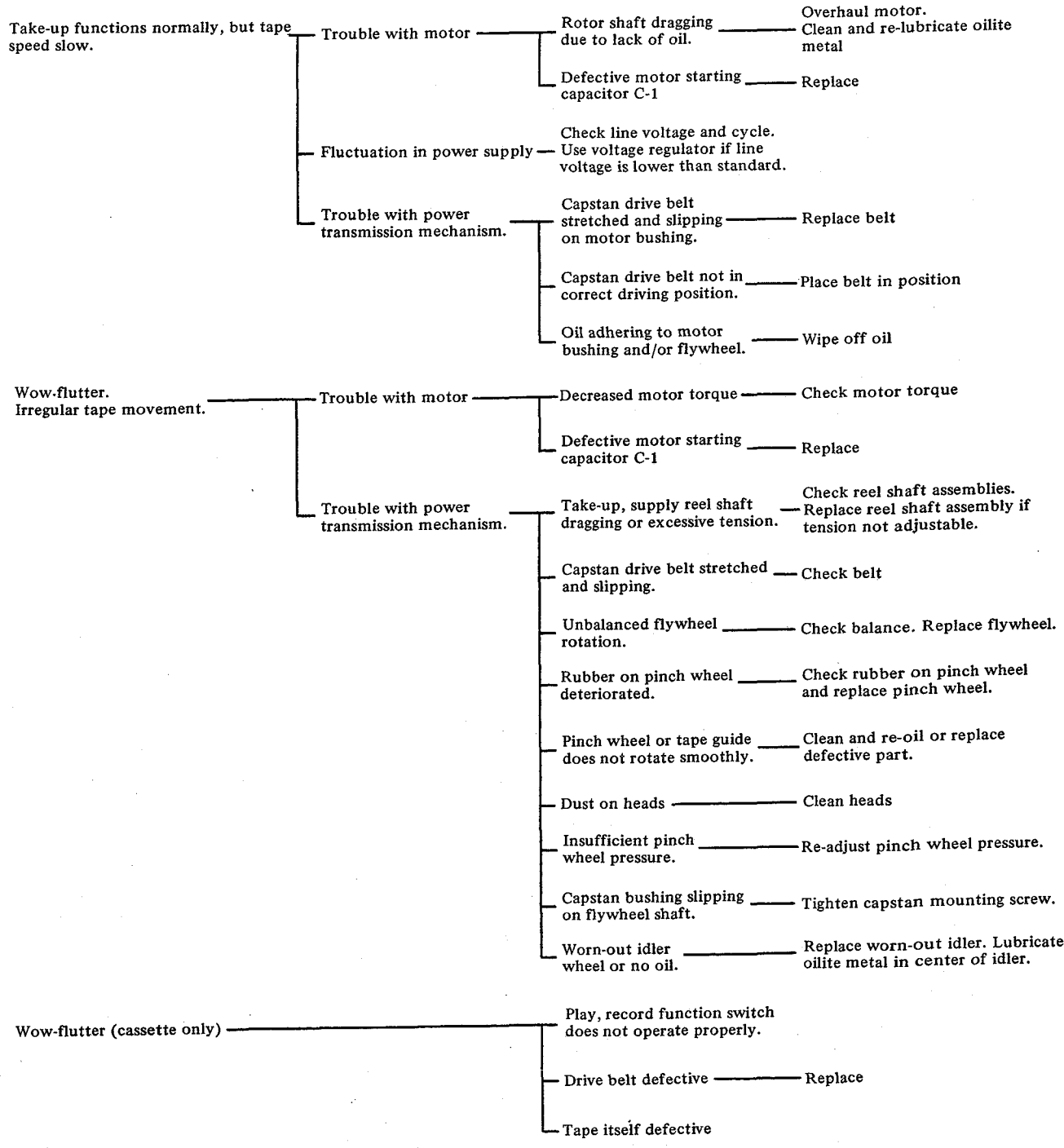



---

**MEMO**

---

**MEMO**

**PRE/MAIN AMPLIFIER P.C. BOARD (RCC-515B)**

For easy repair, patterns of both Sides of this P.C. Board are shown in the Service Manual.  
By placing the transparent sheet on which (RCC-515B) is shown over pattern (RCC-515),  
both sides can be seen at same time.

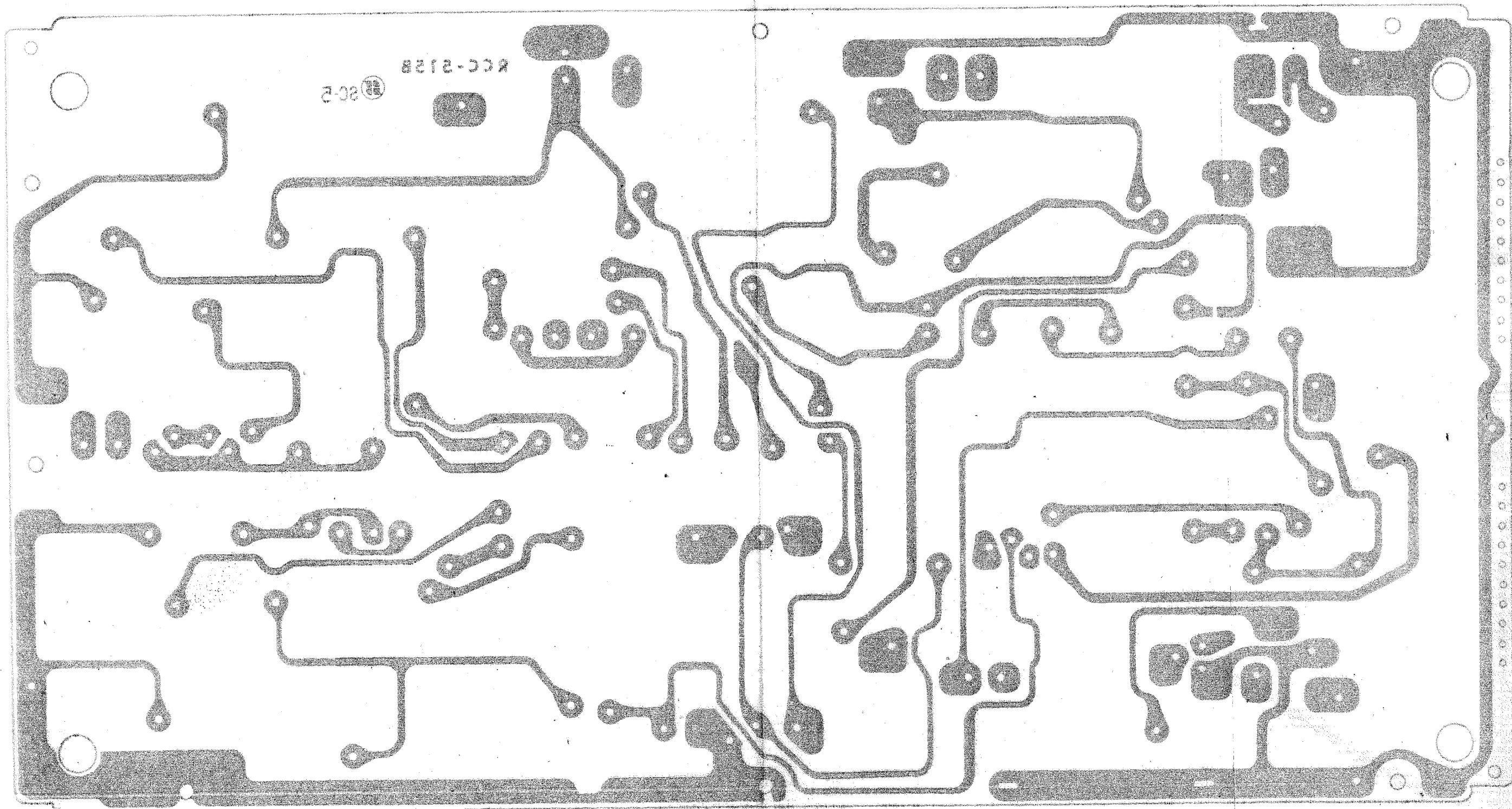





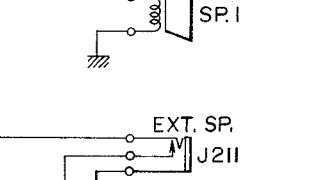
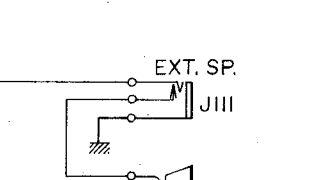
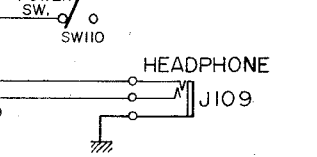
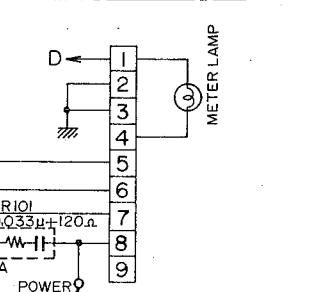
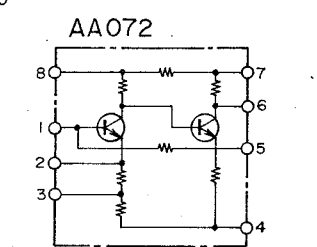
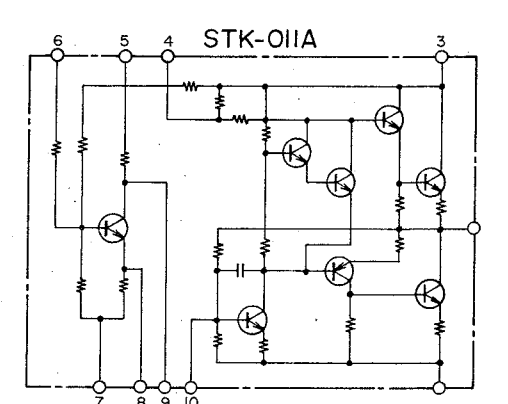
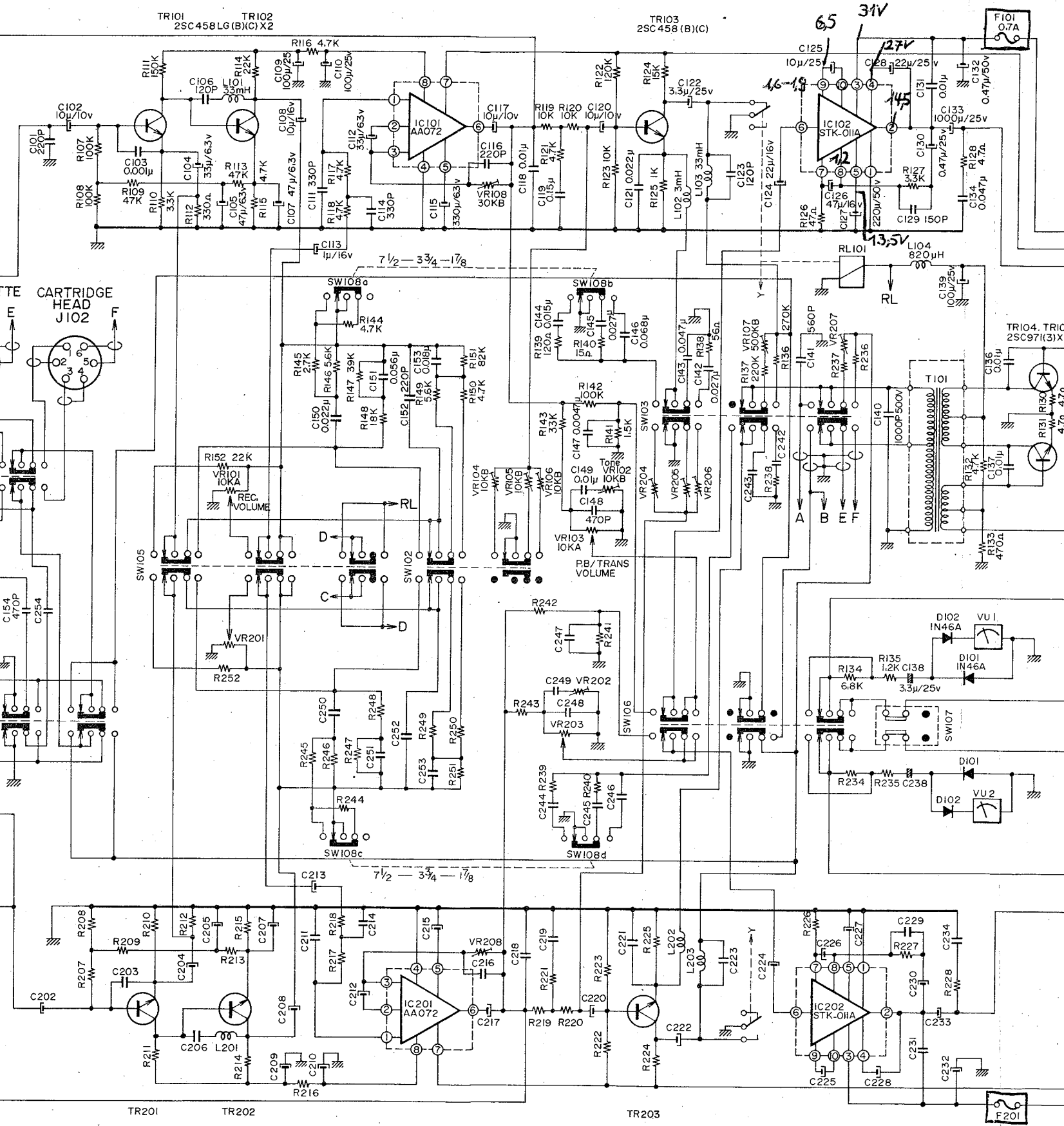
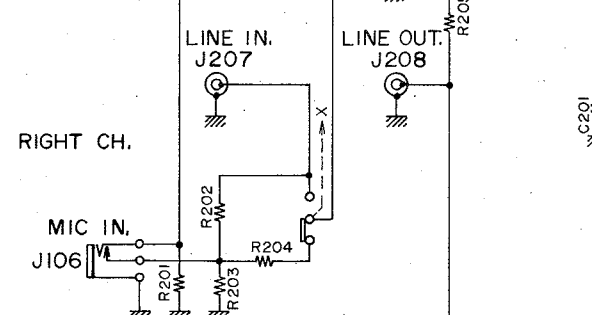
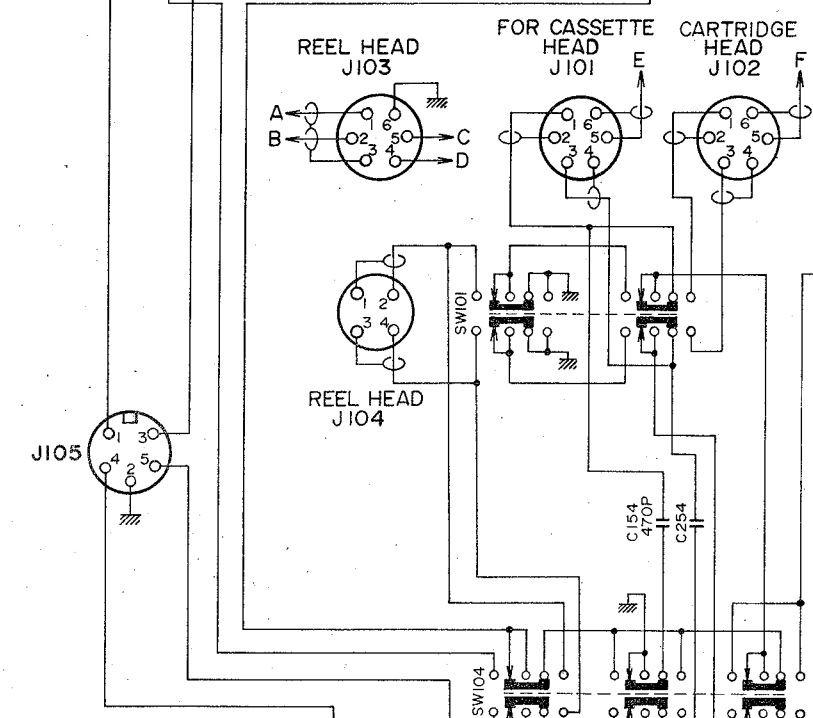
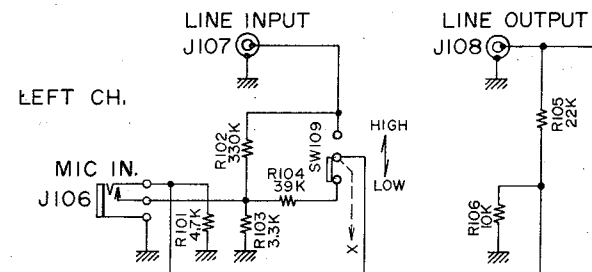

SW101~103 REEL-CASSETTE-CARTRIDGE SW.  
 SW104~106 REC.-P.B.-TRANS. SW.  
 SW107 MUTE SW.  
 SW108(a~d) EQUALIZER SW.

ON AMPLIFIER RCCS SCHEMATIC DIAGRAM  
 RELAY(RL101) IS NOT NECESSARY

X-2000SD AMPLIFIER N02-1  
 SCHEMATIC DIAGRAM 14008041

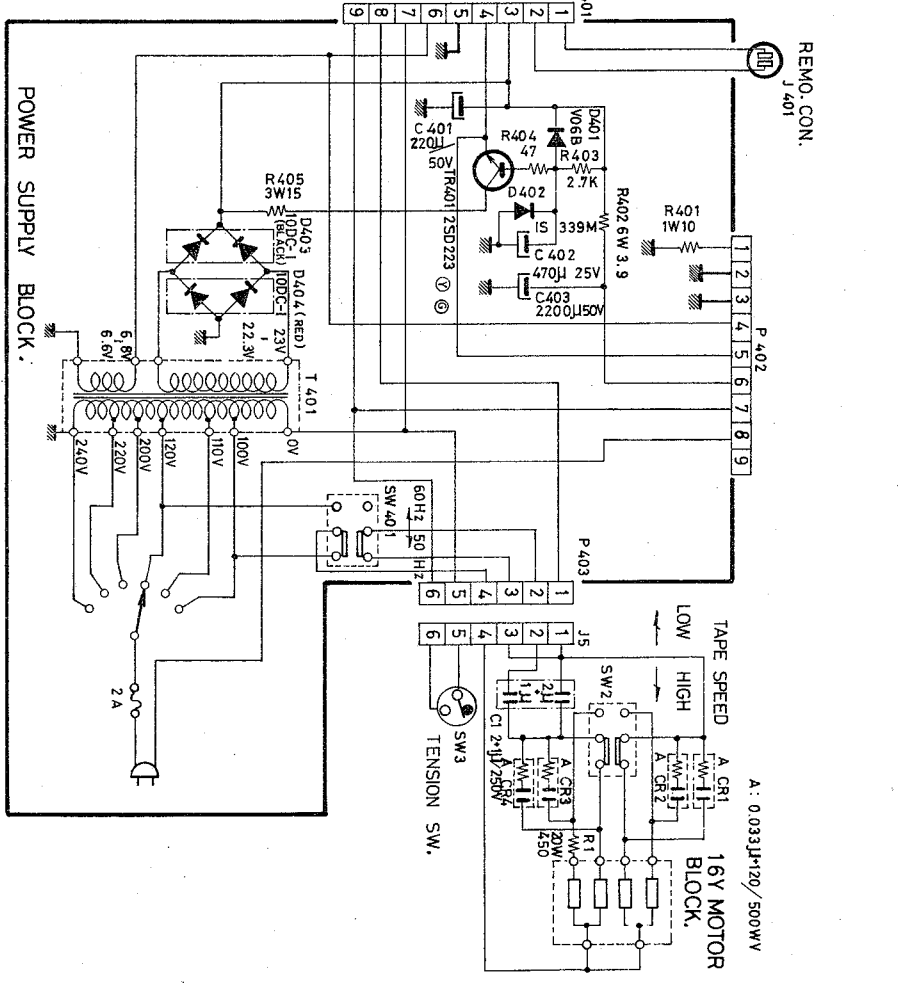
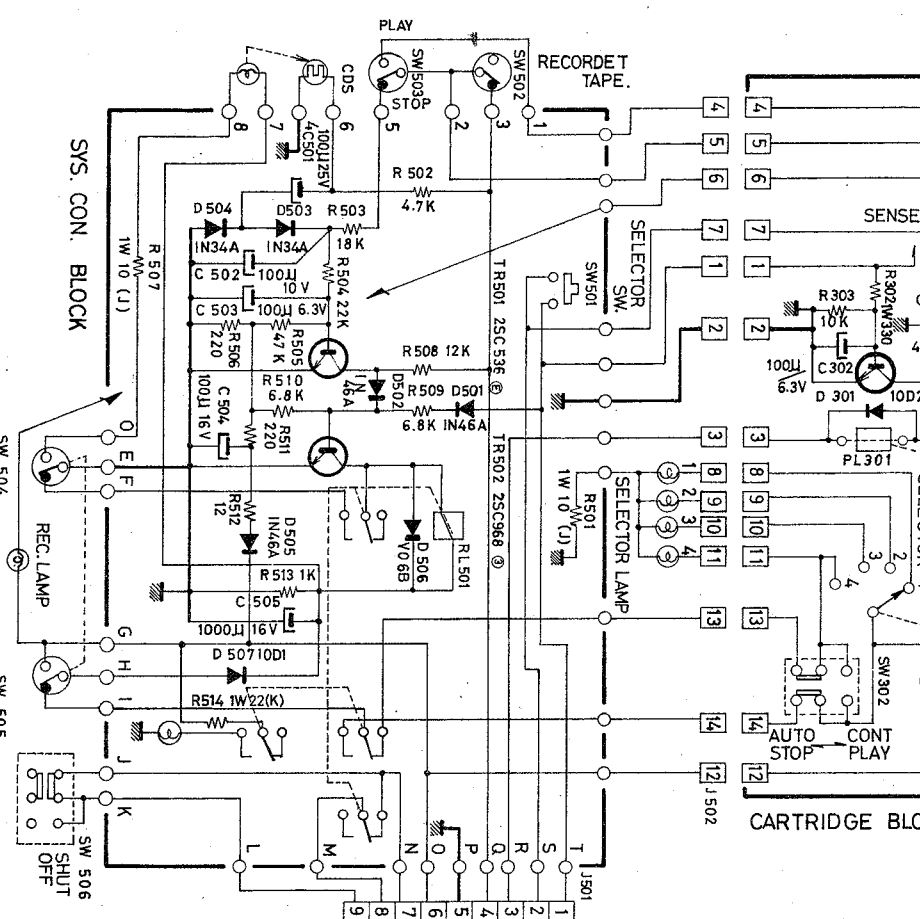
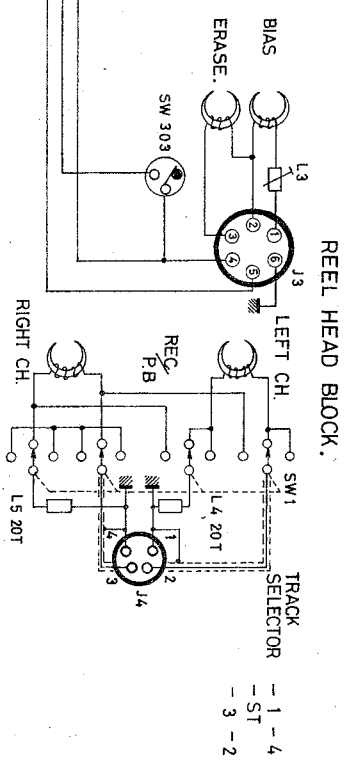
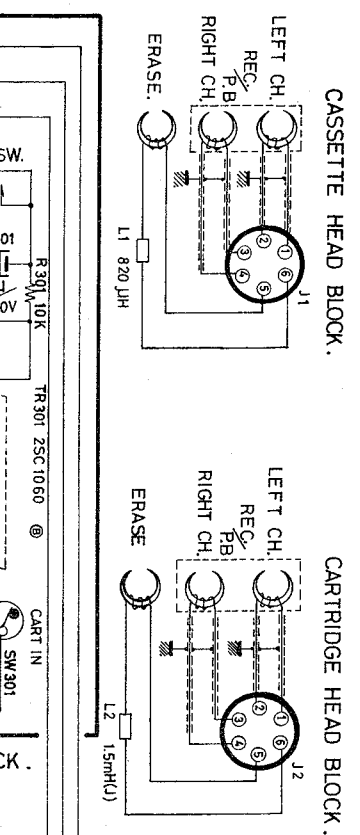

X-2000SD MECHANISM  
SCHEMATIC DIAGRAM NO. 2-2. 14008062

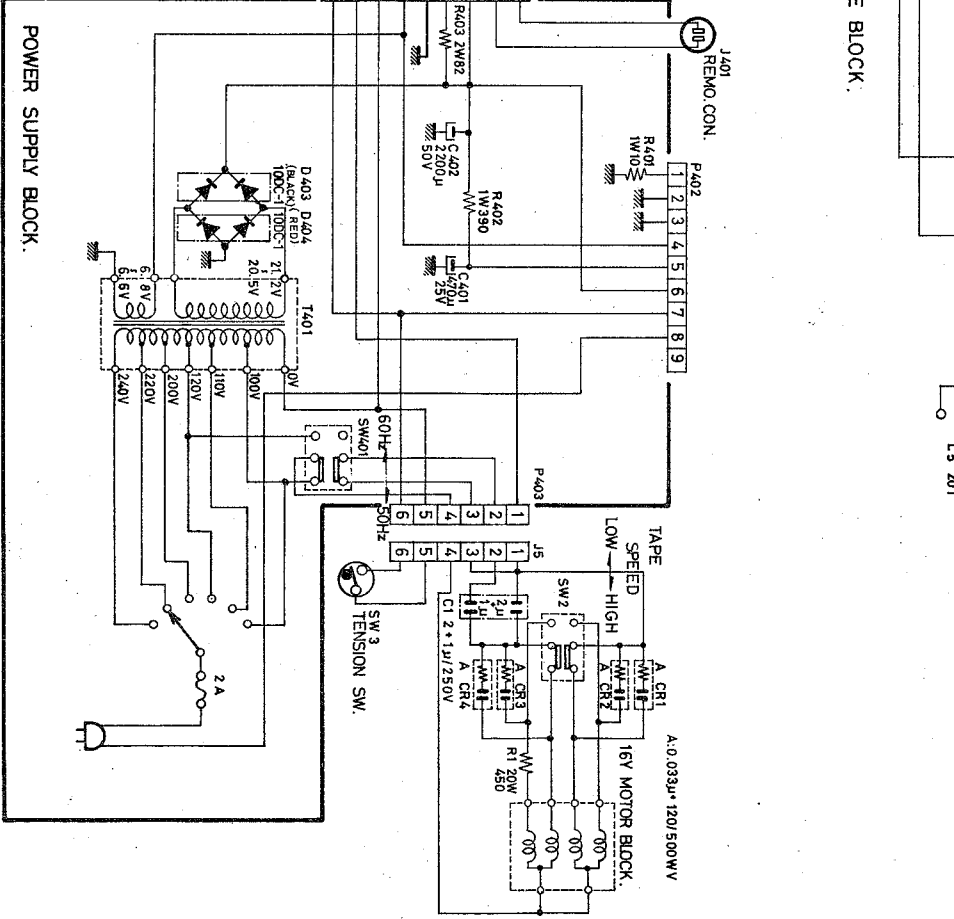
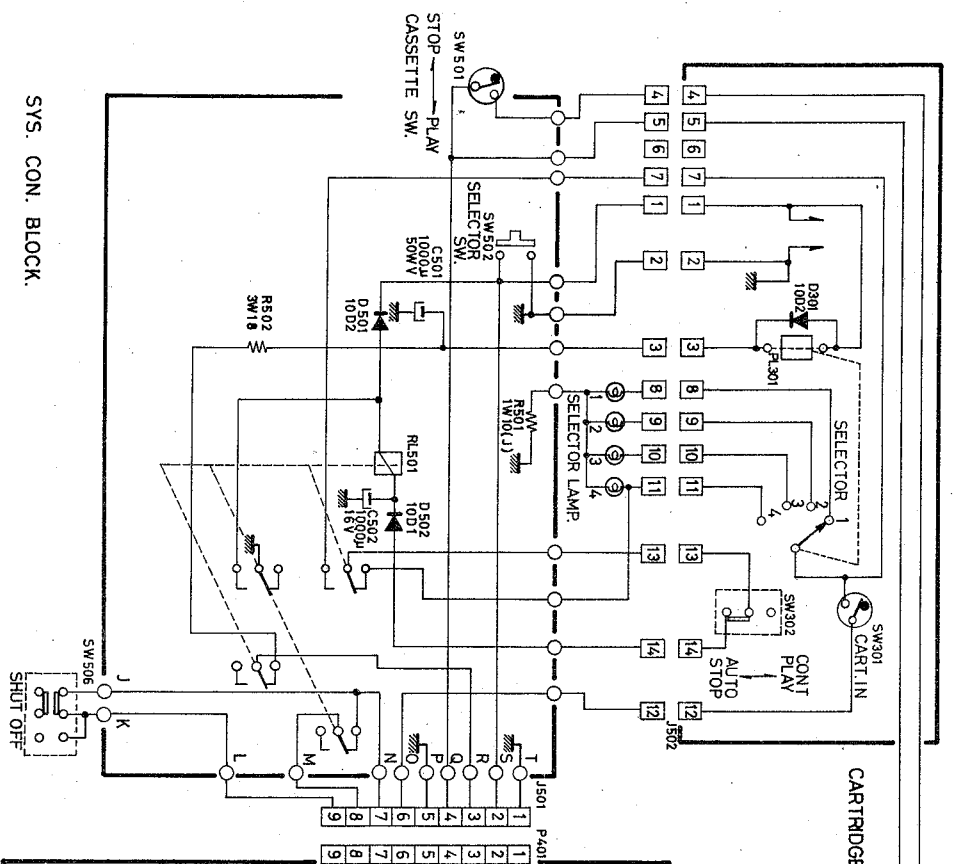
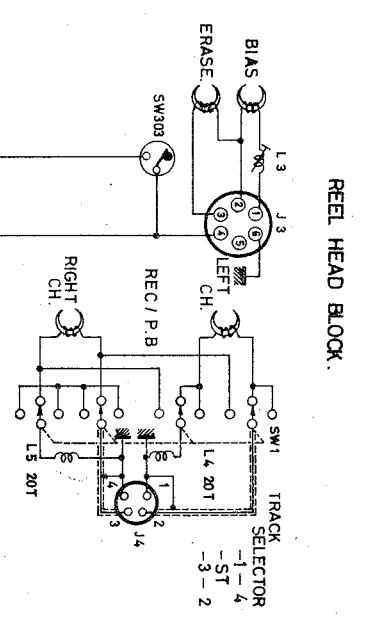
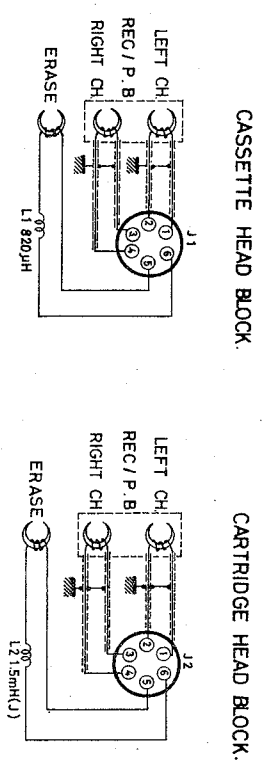

RCCS MECHANISM  
SCHEMATIC DIAGRAM NO. 2-2b 14008081